



## Installation and Maintenance Manual for SPANCO® Freestanding Workstation Bridge Cranes



# TABLE OF CONTENTS

Design Factors.....	3
Important Dimensions for Typical Workstation Bridge Crane Installations.....	4-5
Preparation.....	6
Column and Header Installation.....	7
Beam Clip Sizing Chart.....	8
Runway Installation.....	9-10
Splice Installation.....	11
Bridge End Truck Installation.....	12
Runway End Stop Installation.....	13
Festoon Track Extension Installation, 400 Series.....	13
Festoon Track Extension Installation, 500-900 Series.....	14
Runway Festoon Installation.....	15
Hoist Trolley and Bridge Festoon Installation.....	16
Hoist Installation.....	17
Service Connections.....	18
Design Factors.....	19
Appendix Pages	
AP-1 Header to Header Connections.....	20
AP-2 Plain Track Reverse Flush Mount.....	21
AP-3 Runway Hanger Top Mount.....	22
AP-4 Adjustable Method of Column Anchorage.....	23
Warranty and Service Policy.....	24



**This equipment, used as a crane, is NOT, in any way, designed for lifting, supporting, or transporting humans. Failure to follow specified load limitations can result in serious bodily injury or death.**

## **DESIGN FACTORS**

Nameplate bridge capacity represents the rated load on the hoist hook. The load rating of a hoist shall not exceed the bridge rating. SPANCO's design includes an allowance of 15% of nameplate capacity for dead weight of the trolley and hoist. An additional 25% of nameplate capacity is also included for impact.

## **SEISMIC DESIGN RATING**

All SPANCO workstation bridge cranes meet design requirements for installation and use in seismic zone 4, of the uniform building code, the worst earthquake prone areas in North America.

## **SERVICE FACTOR**

All SPANCO workstation cranes are designed for frequent usage (heavy service) as defined:

- System or equipment is used where operational time is up to 100% of the work period and lifted load is at 50% or below rated capacity.
- System or equipment is used where operational time is less than 50% of work period and lifted load is greater than 50% of rated capacity.
- Applications involving vacuums, magnets, or other high impact lifters are considered severe usage and require special design considerations. Please contact factory for special design pricing.
- Consult factory for usage other than moderate and all instances of high cycle rates or high impact applications such as high speed air or electric hoists, vacuum lifters, or magnets.

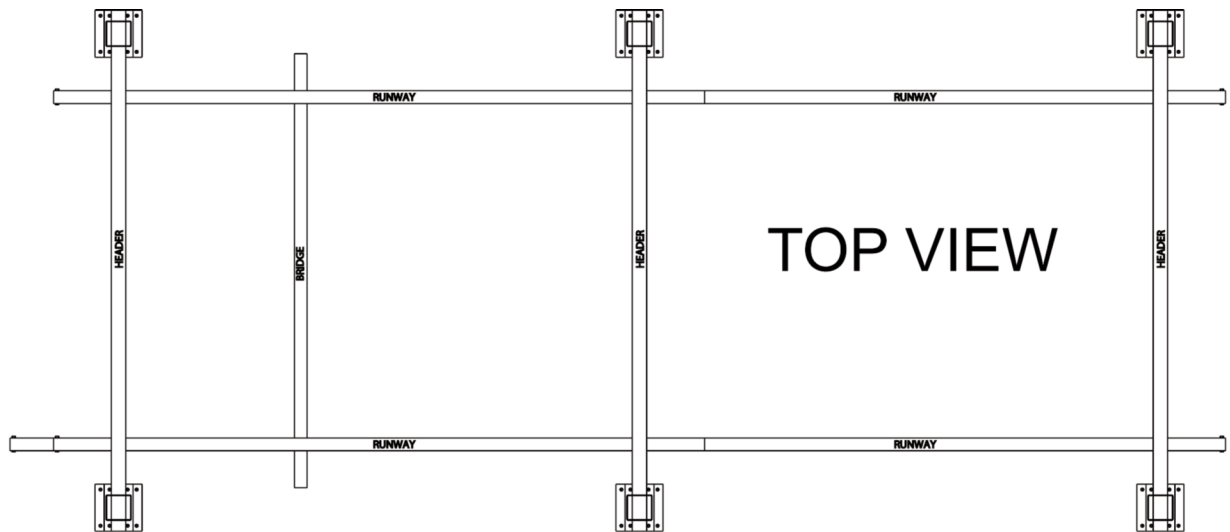

# TOP VIEW

END CANTILEVERS ARE ALWAYS 18", UNLESS ORDERED CUSTOM\*. (EXCEPT 30' SUPPORT CENTERS WHICH ARE 24")

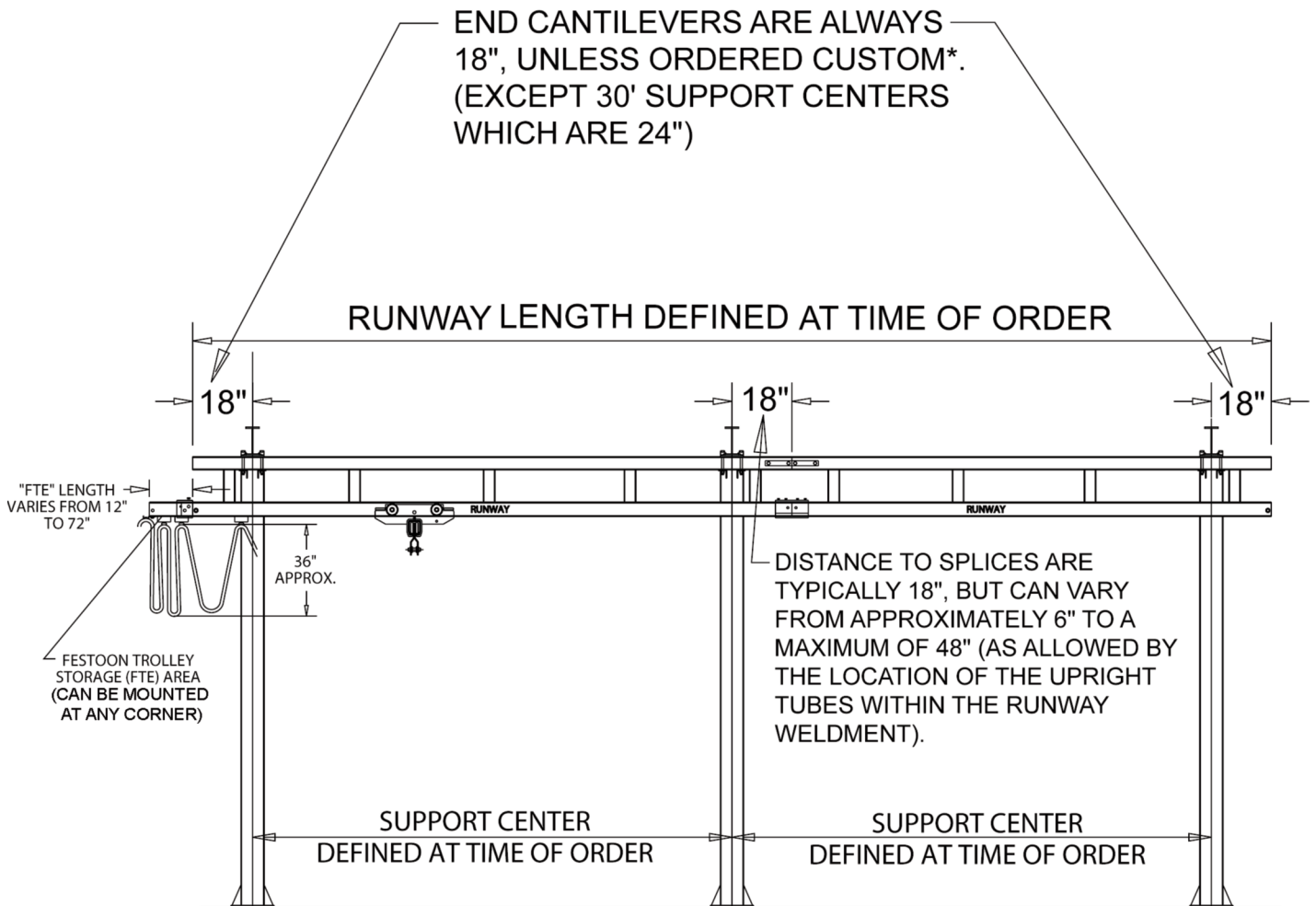

RUNWAY LENGTH DEFINED AT TIME OF ORDER

18"

18"

18"

"FTE" LENGTH VARIES FROM 12" TO 72"

36" APPROX.

FESTOON TROLLEY STORAGE (FTE) AREA (CAN BE MOUNTED AT ANY CORNER)

DISTANCE TO SPLICES ARE TYPICALLY 18", BUT CAN VARY FROM APPROXIMATELY 6" TO A MAXIMUM OF 48" (AS ALLOWED BY THE LOCATION OF THE UPRIGHT TUBES WITHIN THE RUNWAY WELDMENT).

SUPPORT CENTER DEFINED AT TIME OF ORDER

SUPPORT CENTER DEFINED AT TIME OF ORDER

## SECTION VIEW OF RUNWAYS

(VIEWED FROM CENTER OF HEADER)

\*HEAVILY CUSTOMIZED SYSTEMS WILL COME WITH A DETAILED ARRANGEMENT DRAWING

# IMPORTANT DIMENSIONS FOR TYPICAL WORKSTATION BRIDGE CRANE INSTALLATIONS

(A TWO BAY SYSTEM IS SHOWN FOR REFERENCE)

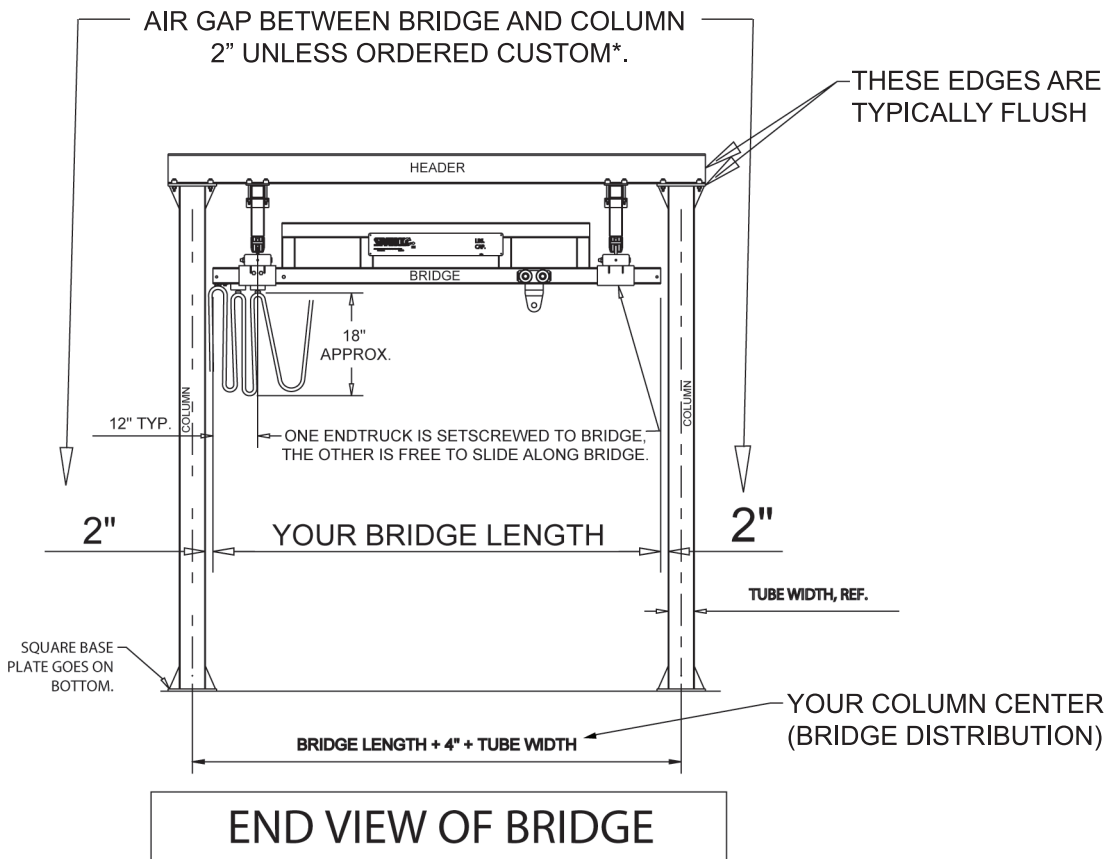
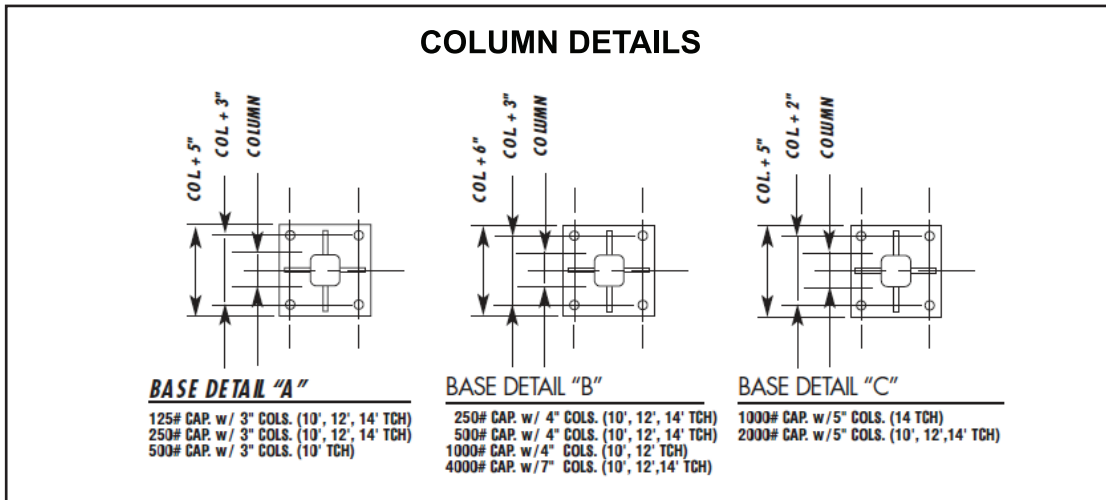

## PREPARATION

1. Before starting the installation, check the material list to be sure you have received all parts. The anchor bolts for the support columns are not included. Four, 13/16" diameter holes are provided for anchor bolts, furnished by others, as required. Sway bracing is recommended and is also furnished by others, as required.

## COLUMN AND HEADER INSTALLATION

2. Lay out area where the crane is to be installed. Bolt the first set of columns to the floor and attach the header beam to columns with 5/8" fasteners. See Figure 1. Torque fasteners to 108 ft. lb. Follow the same procedure for subsequent sets of columns and headers.

See "Column and Header Installation" Figure 1a for more detail.

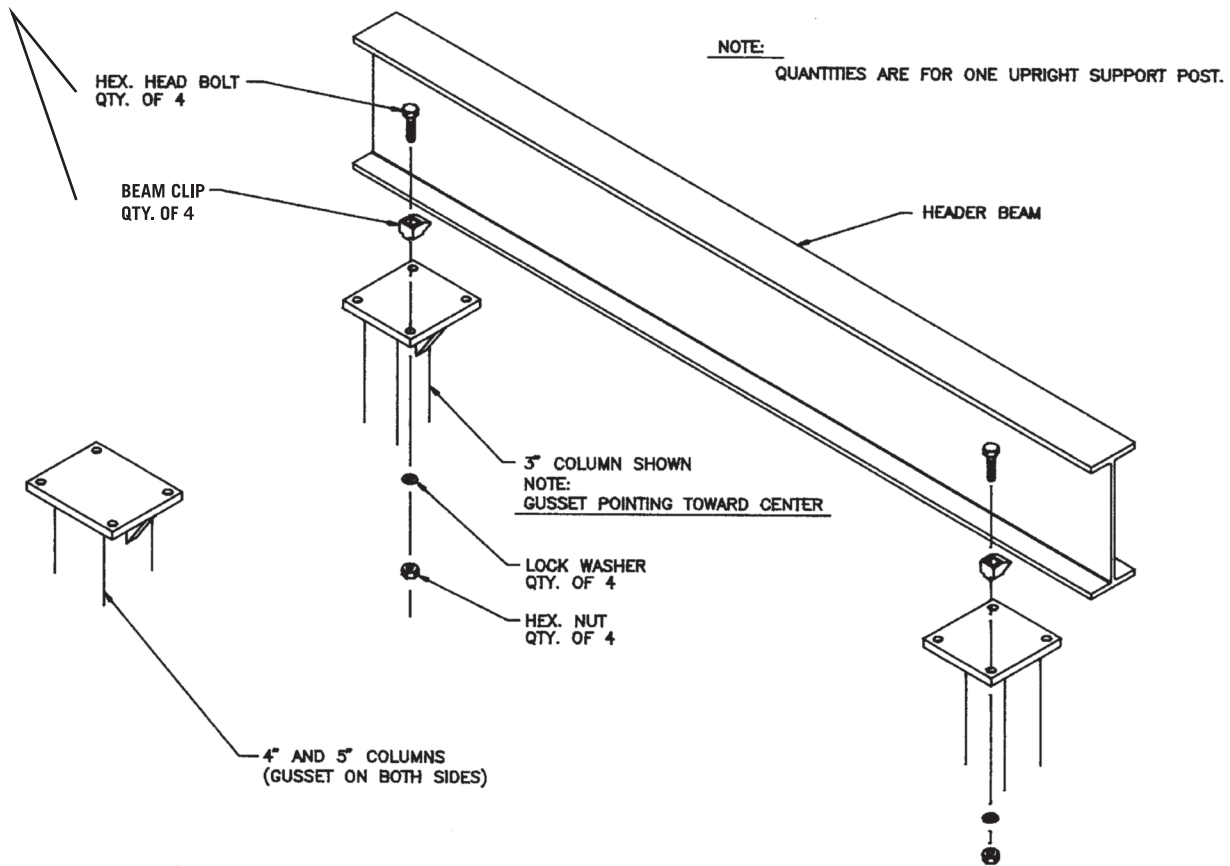

# COLUMN AND HEADER INSTALLATION

Figure 1a

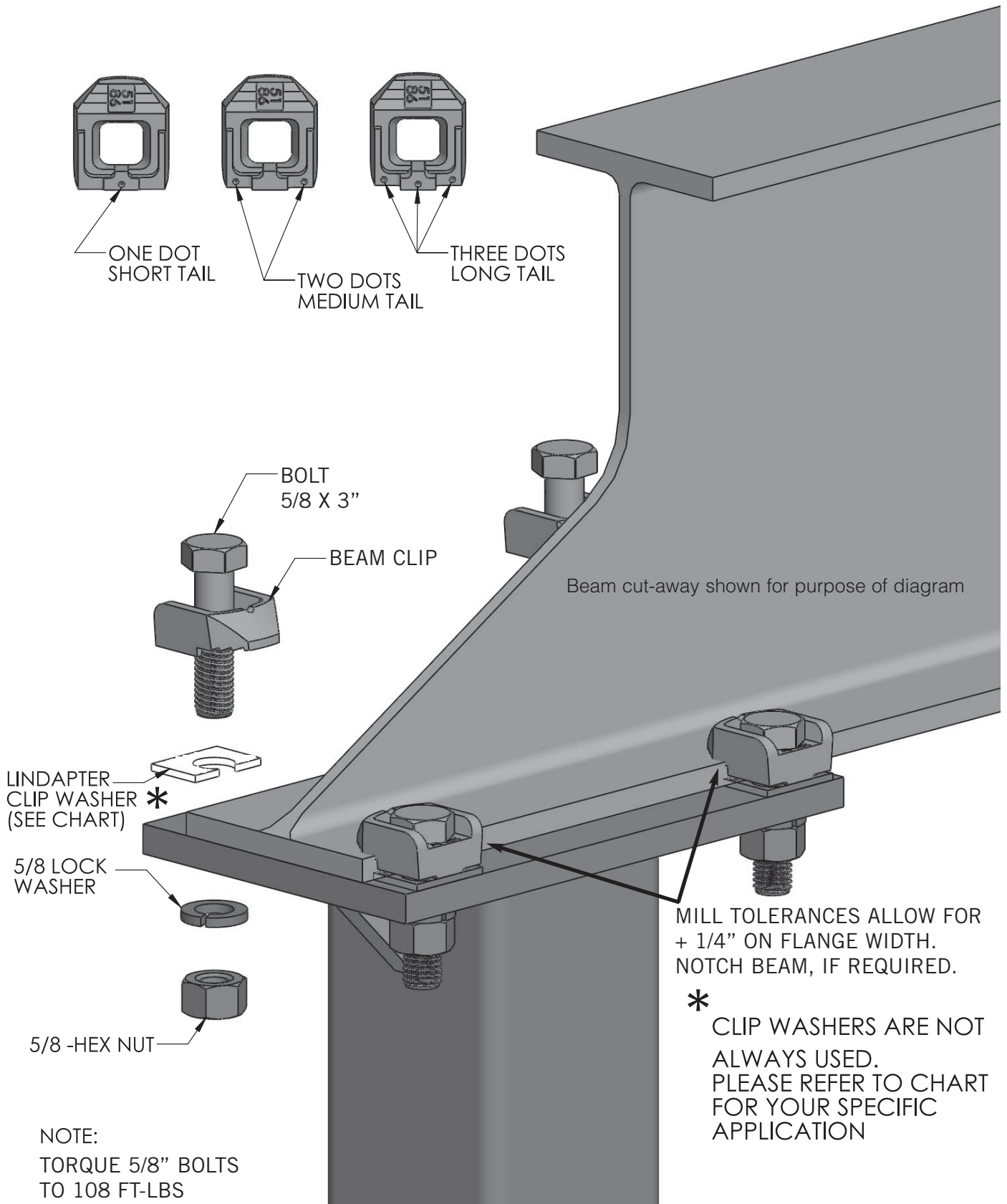

# BEAM CLIP CHART

BEAM THICKNESS (IN)	5/8" DIAMETER BEAM CLIP	3/4" DIAMETER BEAM CLIP
1/4"	S	S
5/16"	M	S
3/8"	S+CW	M
7/16"	L	S+CW
1/2"	S+2CW	L
9/16"	L+CW	M+CW
5/8"	M+P1	L+CW
11/16"	L+2CW	S+P1
3/4"	L+P1	S+3CW
13/16"	L+3CW	M+P1
7/8"	M+2CW+P1	M+3CW
15/16"	M+2P2	M+CW+P1
1"	L+2CW+P1	S+2CW+P1

**S = SHORT TAIL**

**M = MEDIUM TAIL**

**L = LONG TAIL**

**CW = CLIP WASHER**

**P1 = PACKING**

**P2 = PACKING**

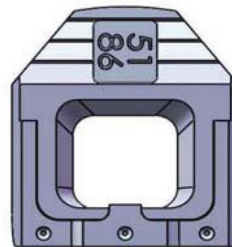
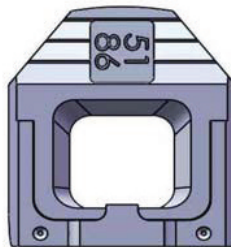
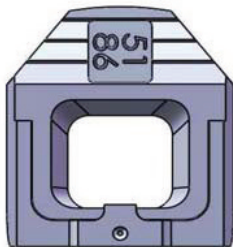
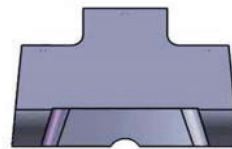
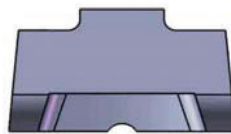
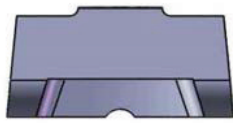

**SHORT TAIL  
(1) DOT**

**MEDIUM TAIL  
(2) DOT**

**LONG TAIL  
(3) DOT**

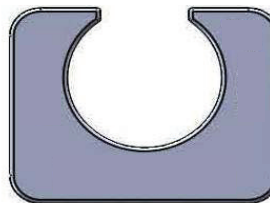
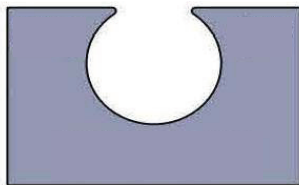

**CLIP WASHER  
(CW)**

**PACKING  
(P1)**





## RUNWAY INSTALLATION

- Using caution not to disturb the columns, raise the runway track into position and clamp it to the header beams with 5/8" fasteners, see Figure 2. Torque fasteners to 108 ft. lbs. Do not cantilever the ends of the runway tracks more than 18" beyond the support centers. The center of runway is located approximately 14" from the inside edge of the support column. OSHA regulations require a minimum clearance of 2" from the end of the bridge track to the face of the support columns or other obstructions.

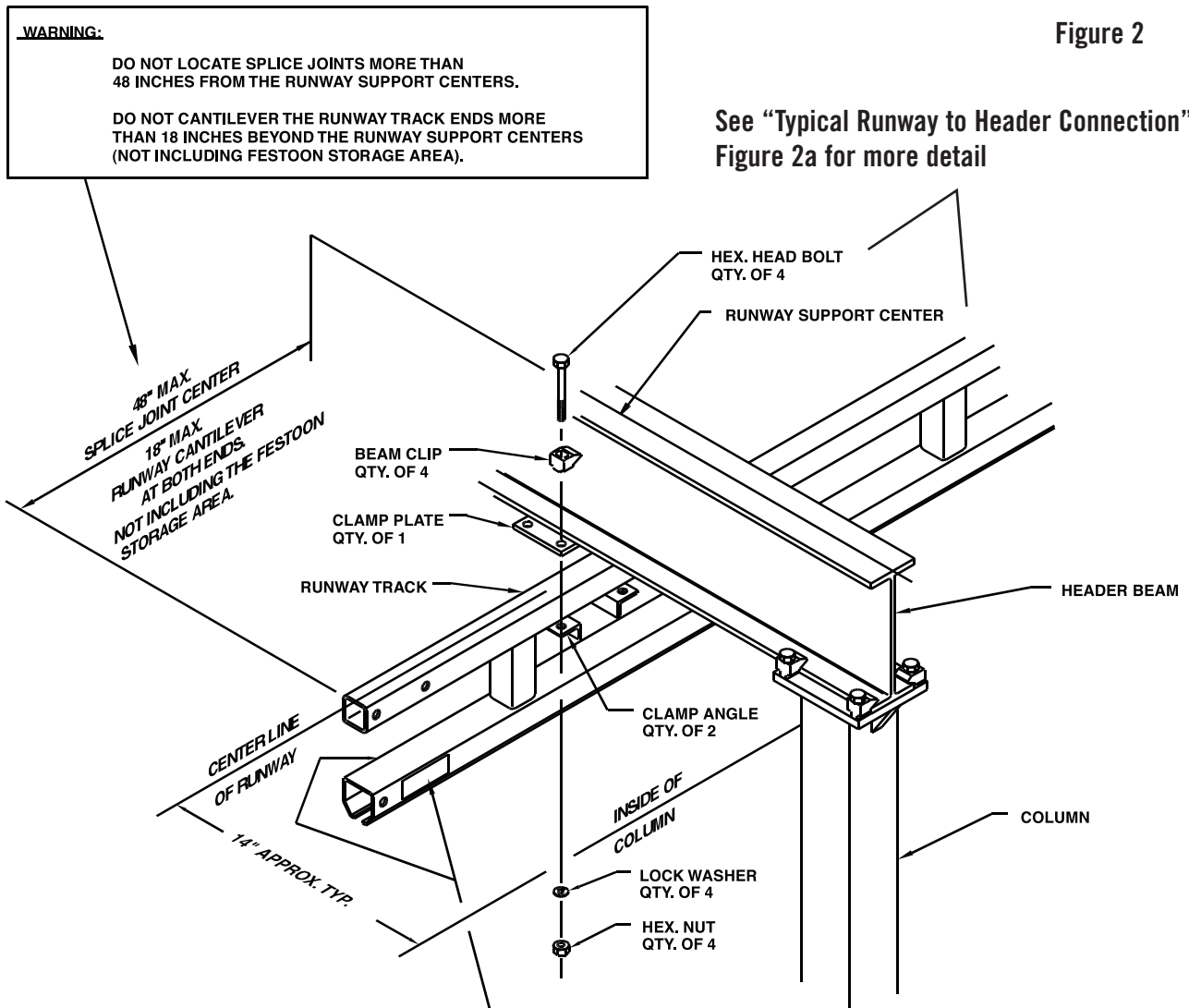

<p>P/N 53-0047</p>	<p><b>WARNING</b></p>
	<p>TO PREVENT TROLLEY/END TRUCK RUNNING OUT OF THE TRACK DO NOT OPERATE CRANE WITHOUT END STOP BOLTS FIRMLY SECURED IN PLACE ON EACH END OF THE BRIDGE CRANE TRACK AND ON EACH END OF EACH RUNWAY TRACK.</p>

**NOTE**

QUANTITIES ARE FOR ONE SUPPORT HANGER.

WARNING LABEL ON BOTH SIDES OF BOTH ENDS.

**TYPICAL RUNWAY TO HEADER CONNECTION**

**Figure 2a**

TYPICAL HANGER KIT

- 4-BOLTS
- 4-BEAM CLIP  
(MAY REQUIRE CLIP WASHERS  
OR PACKINGS)
- 1-"PCT" PLATE
- 2-"ACT" BRACKET
- 4-FLAT WASHERS
- 4-LOCK WASHERS
- 4-NUTS

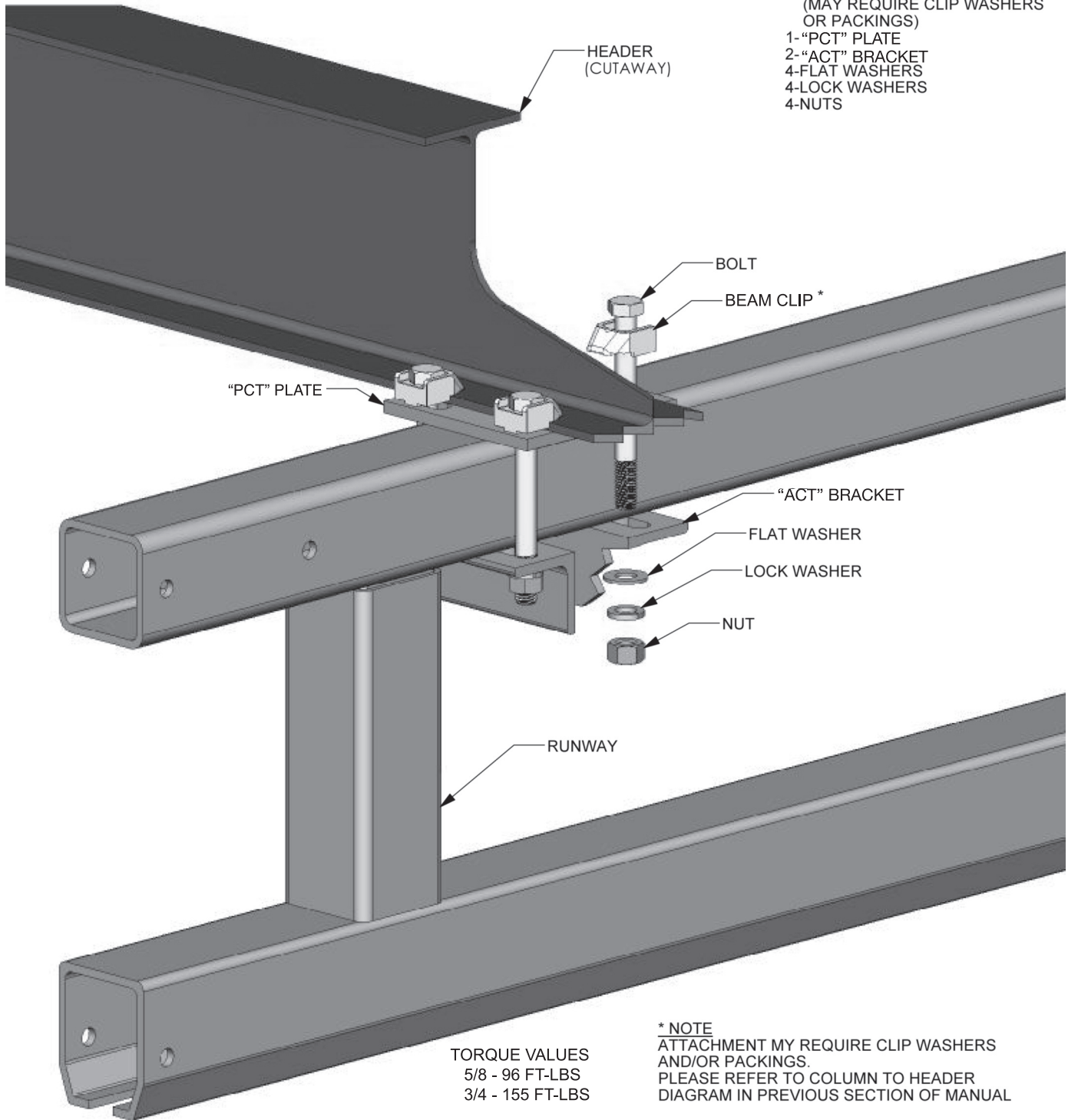

TORQUE VALUES  
 5/8 - 96 FT-LBS  
 3/4 - 155 FT-LBS

\* NOTE  
 ATTACHMENT MAY REQUIRE CLIP WASHERS  
 AND/OR PACKINGS.  
 PLEASE REFER TO COLUMN TO HEADER  
 DIAGRAM IN PREVIOUS SECTION OF MANUAL

## SPLICE INSTALLATION

4. If your system has more than one section (length) of runway track, each additional section is installed in the same manner as the first, with the addition of a splice joint assembly.

The track splice joint is made using a sleeve with a total of eight set screws threaded into the top and both sides. Slide the sleeve over the end of the first runway track, then butt the second runway track against the first. Center the sleeve over the joint. The two center top set screws should be tightened slightly to push the tracks against the base of the sleeve so that the two bottom surfaces of the track are even. Adjust the side set screws so that the track slots are aligned and there is a smooth transition from one track to the other, see Figure 3. Tighten all top set screws then side set screws for correct track alignment. Do not over tighten set screws.

Trussed runway splice joints also include two splice plates and four, 1/2 inch bolts with nuts. Install the splice plates to connect the ends of the truss top tubes with the four through bolts provided. **Torque through bolts to 50 ft. lb.**, see Figure 3.

Trussed Runway: Splice joints should be within 48" of a support hanger as shown in Figure 3. Refer to Figure 4, page 12, for splice joint track alignment.

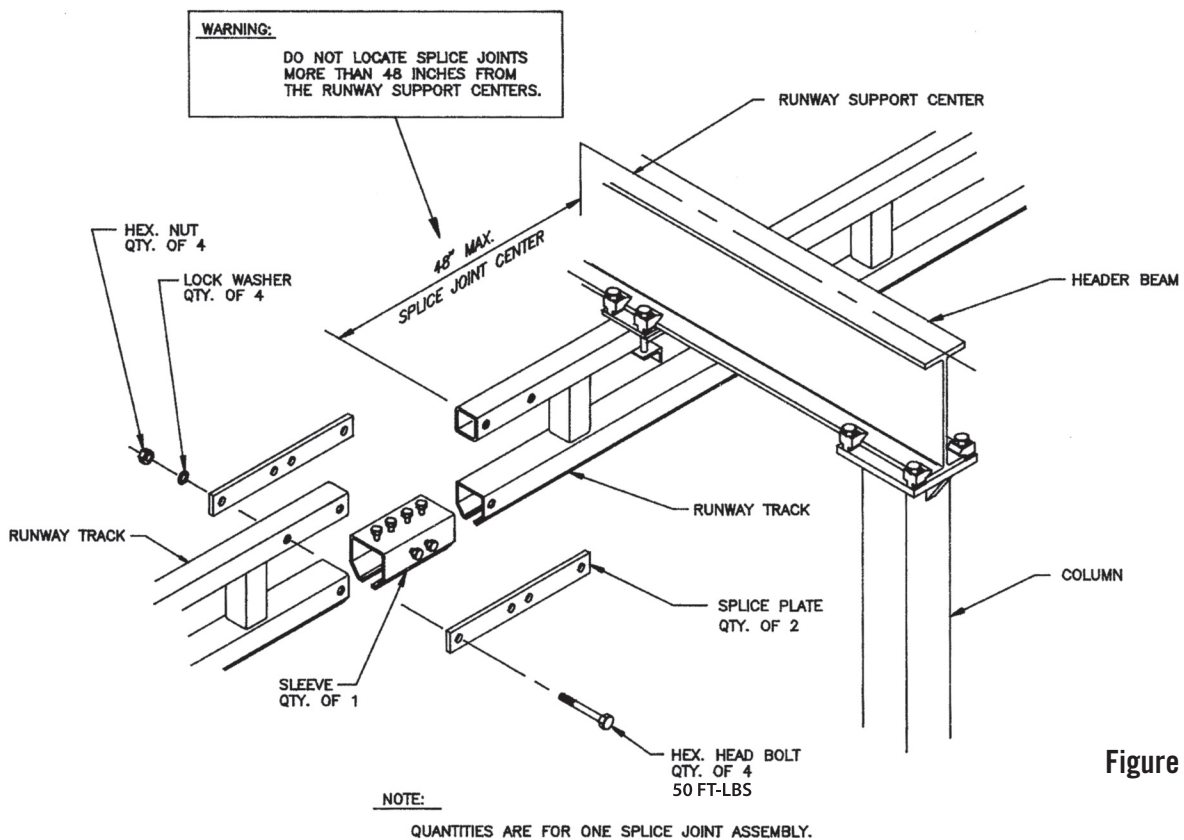
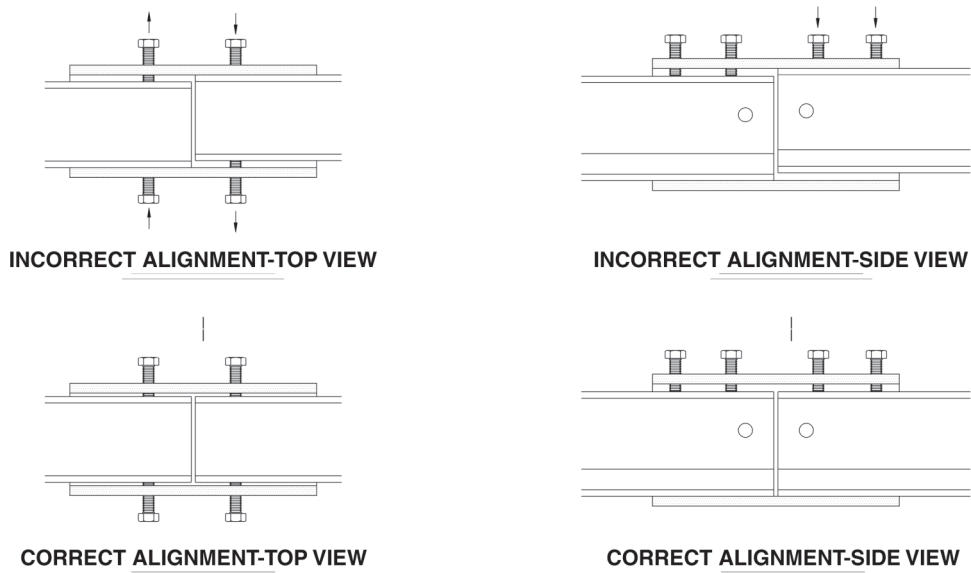

Figure 3

**Figure 4**



**BRIDGE END TRUCK INSTALLATION**

6. Insert the bridge track into the sleeves of the end trucks. Locate the center of the end trucks approximately 12” from each end of the bridge. One end truck is secured to the bridge track with set screws, furnished with the sleeve. The other end truck is allowed to slide freely on the bridge track in order to accommodate any slight misalignment between the parallel runway tracks, see Figure 5. Install the bridge crane by inserting the end trucks of the runway tracks at one end of the runway. Adjust and tighten the bridge end truck set screws to provide a minimum clearance of 2” between the ends of the bridge and the support columns.

**Figure 5**

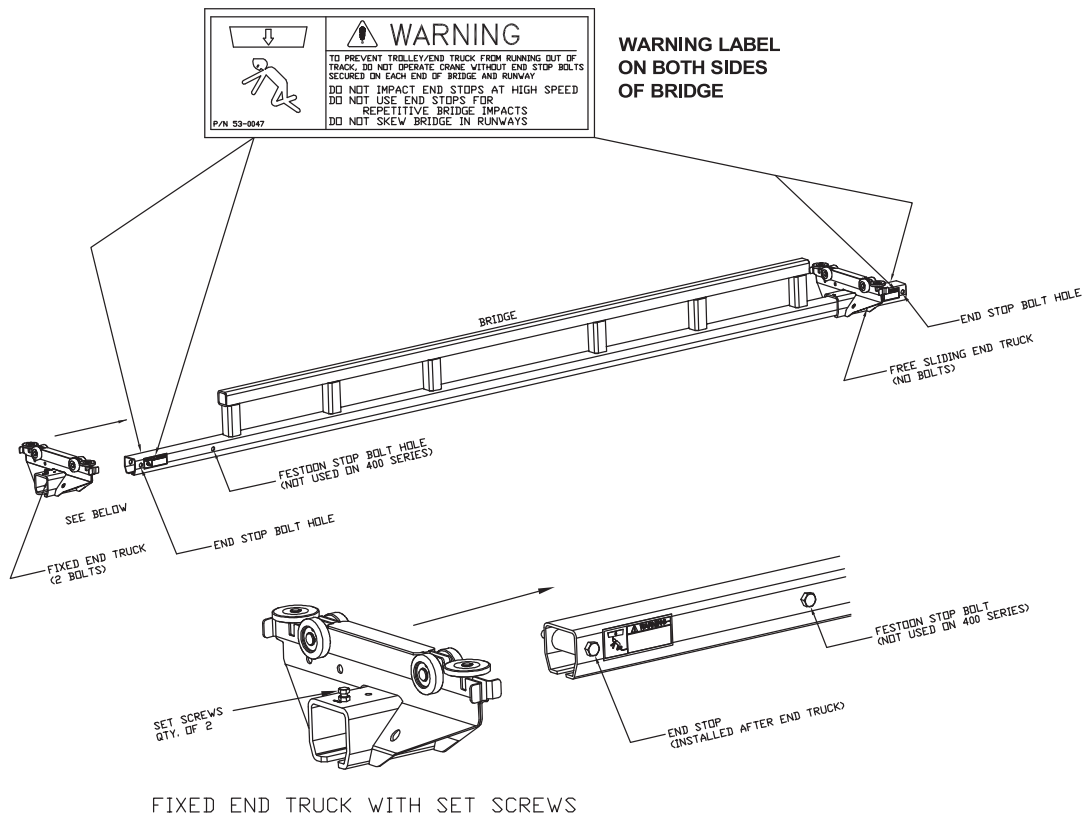

## RUNWAY END STOP INSTALLATION

- Secure end stop assemblies, end stop bolts, and lock nuts at both ends of both runway tracks, except for the end of the festoon storage area, where applicable. See Figures 6a and 6b.

## FESTOON TRACK EXTENSION INSTALLATION

- Place festoon track extension on end of runway as close as possible to the power junction box. Align the festoon track extension prior to tightening any bolts. Adjust bolts in the side of the festoon track extension to ensure alignment of bottom flanges of track. Clamp festoon track extension firmly into a level, straight position prior to tightening the top of the extension. Check to ensure that all surfaces of the track ends and the festoon track extension are in contact. Tighten top bolt to:

400 Series	12 ft. lb.
500-900 Series	17 ft. lb.

### 400 Series Track

Install special 1/4" through bolt in top of festoon track extension. See Figure 6a. Place flat washer and lock nut on through bolt and tighten. Do not place end stop at this location. Using end stop supplied with the system, install in the end of the festoon track extension.

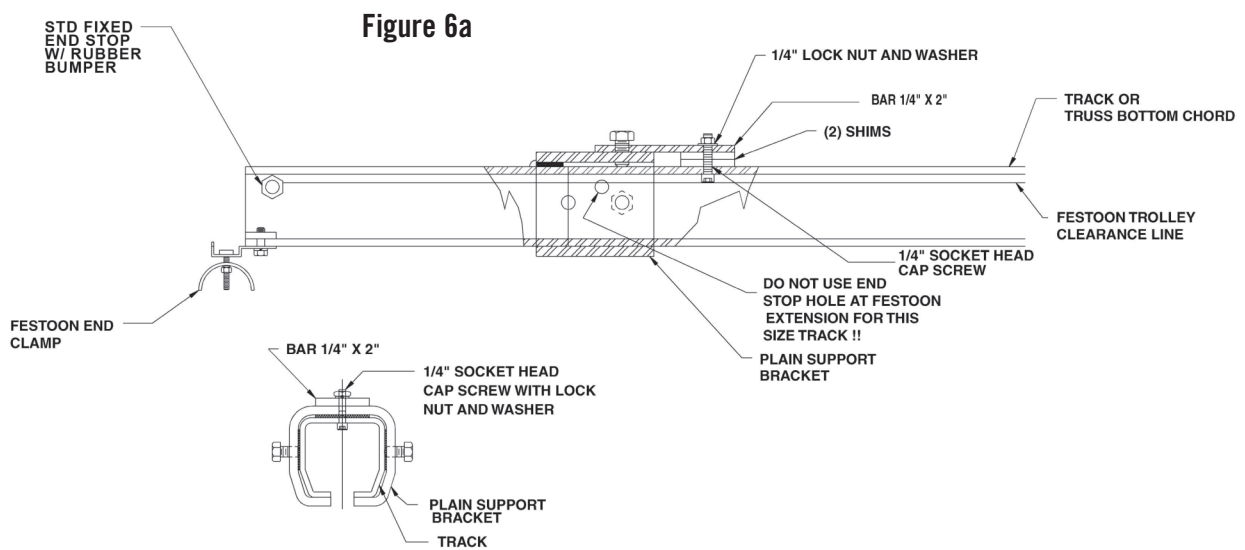

## 500-900 Series Track

Install through bolt through side of festoon track extension. See Figure 6b. Place lock nut on through bolt and tighten. Do not place end stop or end stop bumper supplied with system at this location.

Using end stop supplied with the system, install in the end of the festoon track extension.

**Note: ALL endstop bolts must have the rubber bumper to ensure the festoon trolleys remain in the track.**

Ensure that all end stop warning labels are in place.

Install festoon end clamp to secure festoon cable at the end of the festoon track extension.

Ensure the trolleys slide across the runway and festoon track extension joint smoothly. Make necessary adjustments.

Ensure all trolleys stack properly in festoon track extension area, clear through bolts, and contact the end stop.

Figure 6b

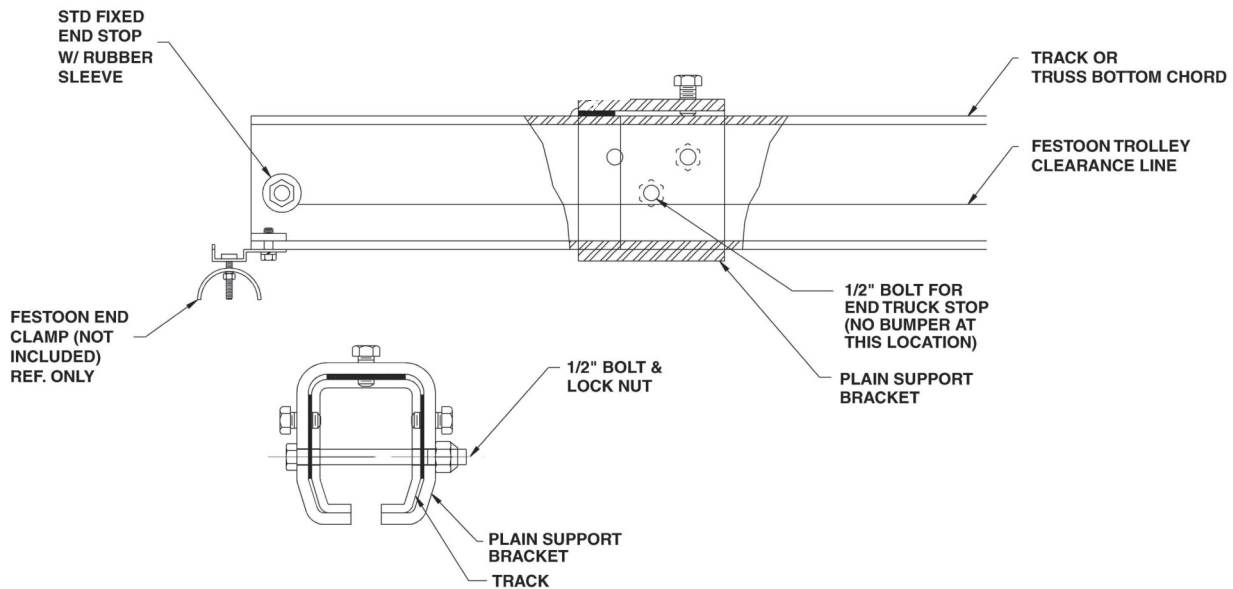

## RUNWAY FESTOON INSTALLATION

- Install festoon trolleys into the storage area of runway track if system includes festooning. Secure end stop bolts and rubber bumpers. Locate and secure festoon end clamps as shown in Figure 7. Install the festoon cable on the festoon trolleys at equal spacing, approximately 6' 7" apart for approximate 36" loops. Festooning can be located on any end of runway.

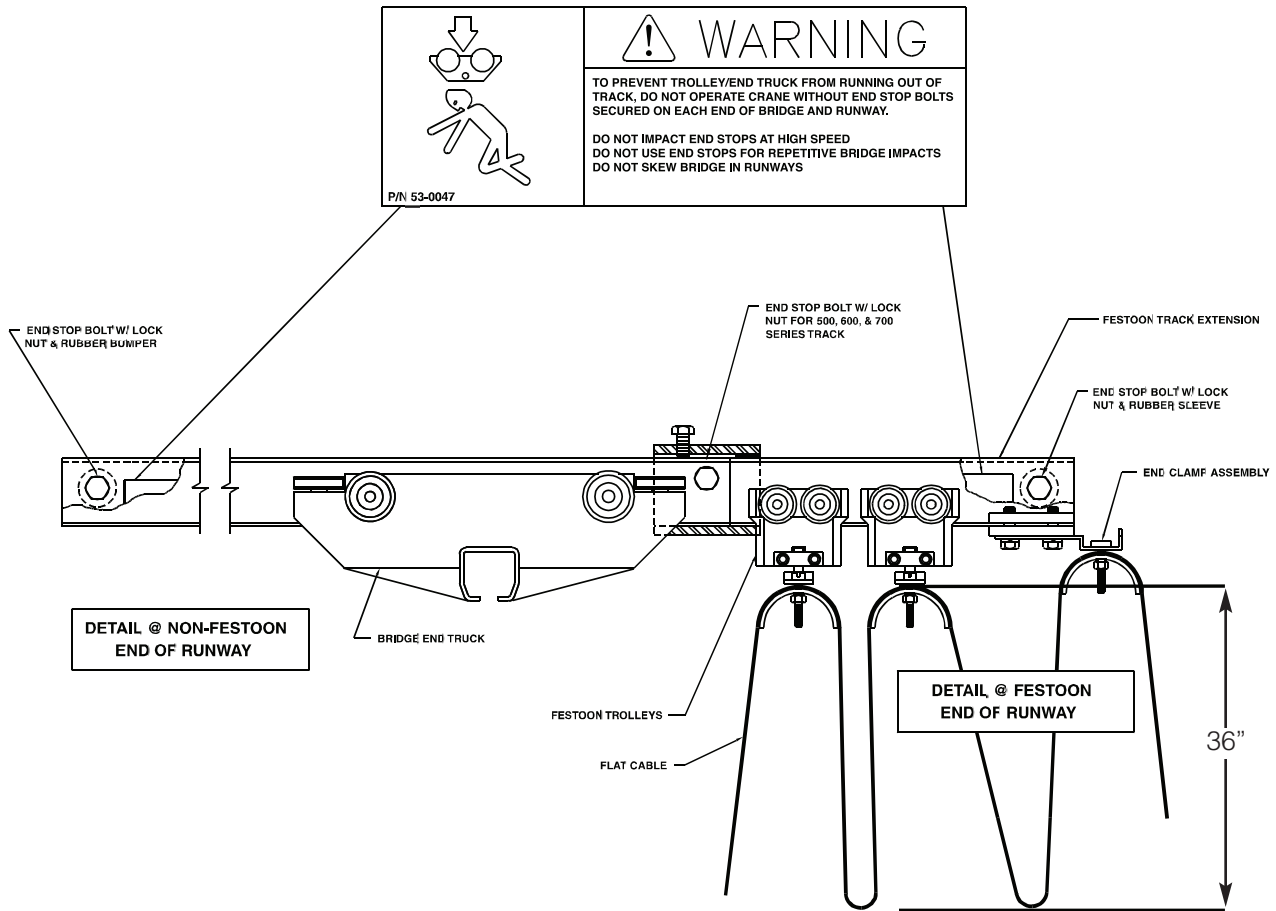
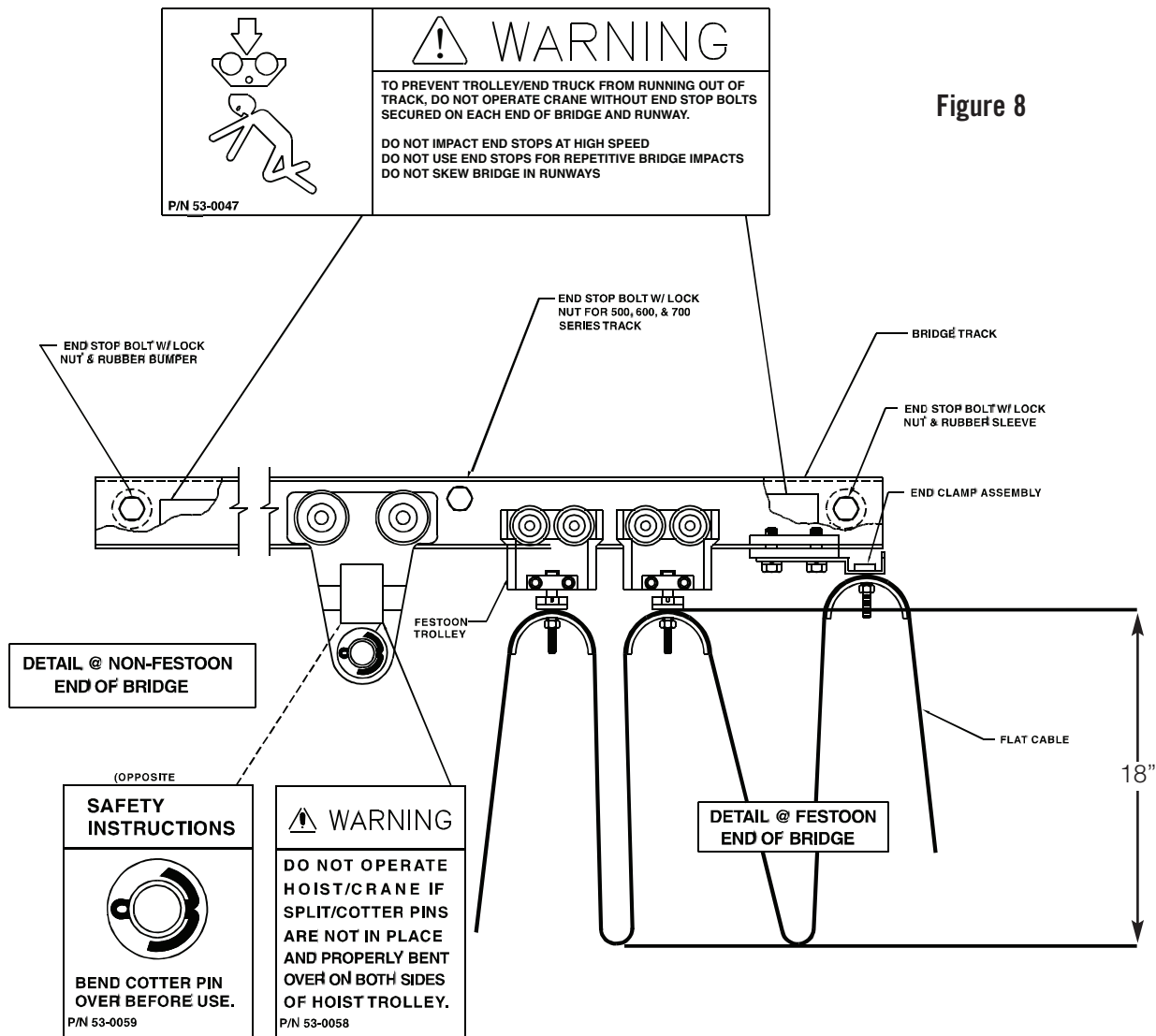

**Figure 7**  
**Runway Festoon Detail**  
**(or Monorail Festoon Detail)**

## HOIST TROLLEY AND BRIDGE FESTOON INSTALLATION

- Install hoist trolley and festoon trolleys on bridge track, if applicable, as shown in Figure 8. Secure end stop bolts and rubber bumpers, also shown in Figure 8. Install the festoon cable on the festoon trolleys at equal spacing, approximately 3'4", for approximate 18" loops. Festoon storage area is within the bridge length.

Once installation is completed, the bridge and runways should be leveled. The total system should then be checked for tightness of all nuts and bolts.





## HOIST INSTALLATION

10. Attach hoist supplied by others to hoist trolley. **Use washers on hoist mounting pin to center hoist inside hoist trolley. Reinstall washer on outside of hoist trolley (both sides) before installing or reinstalling cotter pins to secure hoist mounting pin.** Replace cotter pin(s) if worn or broken. Bend cotter pin around mounting pin, see Figure 9.

**WARNING:** Do not operate hoist or crane if cotter pins are not in place and properly bent over on both sides of hoist trolley. Check regularly that the cotter pins are in place and securing the hoist on the hoist trolley.

Figure 9

**NOTE:** Some trolley load pins only have one cotter pin.

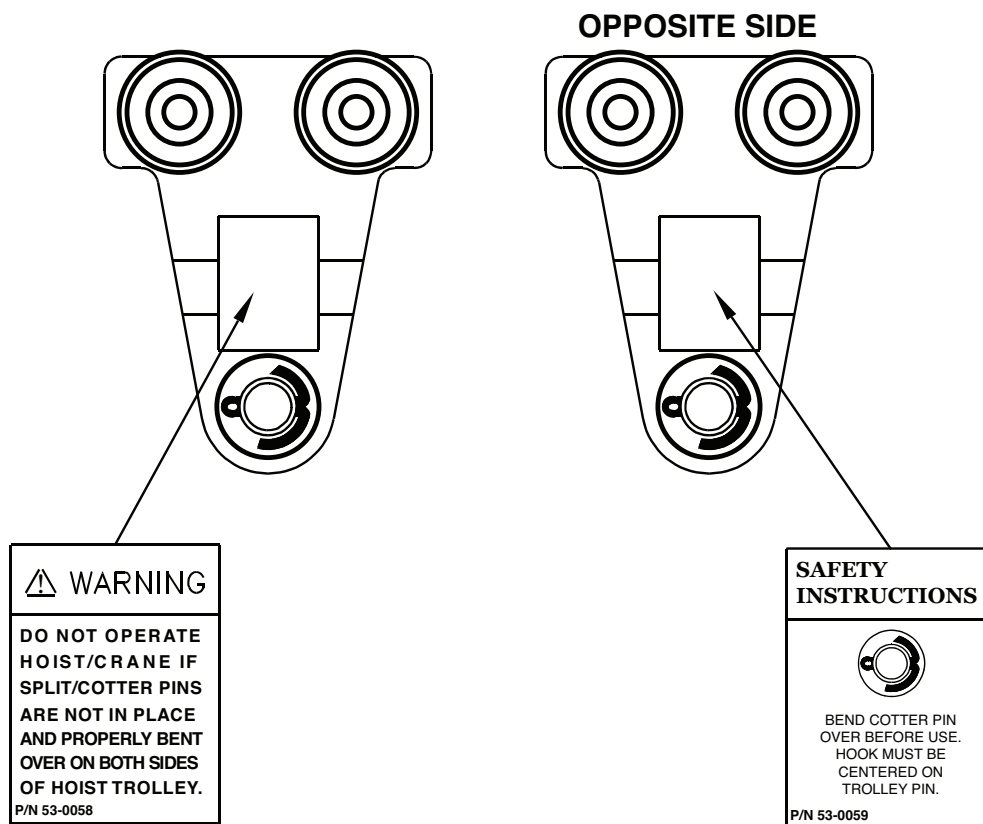

## SERVICE CONNECTIONS

11. Where applicable, follow the supplemental circuit diagrams to make service connections, such as electrical power. Make sure services are not energized while making any connections and that they match the specified supply on the circuit diagram.

## WARNING, SAFETY, OR CAPACITY LABELS

12. If at any time these labels are lost, stolen, removed or become illegible, contact SPANCO at 800-869-2080 for free replacements. Please order by part number on the label or by the facsimiles in this manual.

## ACCEPTANCE TEST

After the workstation crane or monorail system has been installed, OSHA requires an acceptance test before operating and also after any modifications. This acceptance test should be performed by an authorized dealer or installer.

## IMPORTANT MAINTENANCE INFORMATION

At the end of the first month after a new installation, an inspection of the system should be performed. All nuts, bolts and screws should be checked for tightness. All end stops, cotter pins, and hoist trolleys should be checked for abnormal wear or breakage. Check all track splices for alignment and that end trucks and festoon trolleys travel smoothly through the joints. Also, check that all festoon cables and/or hoses are securely clamped to the festoon trolleys and end clamps. Adjust as necessary.

Thereafter, a complete inspection of all fasteners and connections should be performed annually or every 2000 hrs., whichever comes first. It is important to note that every system application and use will be different, therefore some conditions of use could require more frequent inspection. Examples of such conditions might be two or three shift operations, high, repetitive, fast movement of the crane, or frequent crashing of the crane end trucks or trolley into the end stops.

It is expected that every time an operator uses a workstation crane or monorail system, they visually inspect the system before using it and note any unusual or abnormal operation of the system while using it. Meticulous, careful operation of the system will help minimize system maintenance.

<u>ITEM</u>	<u>CHECK</u>
nuts, bolts, screws.....	tightness
endstops, cotter pins, hoist trolley(s), track, and supports.....	abnormal wear or breakage
track splices.....	alignment and smooth travel through joints
festoon cable/hoses.....	clamped securely, abnormal wear or breakage

**DESIGN FACTORS**

Nameplate bridge capacity represents the rated load on the hoist hook. The load rating of a hoist shall not exceed the bridge rating. SPANCO’s design includes an allowance of 15% of nameplate capacity for dead weight of the trolley and hoist. An additional 25% of nameplate capacity is also included for impact.

**SEISMIC DESIGN RATING**

All SPANCO workstation bridge cranes meet design requirements for installation and use in seismic zone 4, of the uniform building code, the worst earthquake prone areas in North America.

**SERVICE FACTOR**

All SPANCO workstation cranes are designed for frequent usage (heavy service) as defined:

- System or equipment is used where operational time is up to 100% of the work period and lifted load is at 50% or below rated capacity.
- System or equipment is used where operational time is less than 50% of work period and lifted load is greater than 50% of rated capacity.
- Applications involving vacuums, magnets, or other high impact lifters are considered severe usage and require special design considerations. Please contact factory for special design pricing.
- Consult factory for usage other than moderate and all instances of high cycle rates or high impact applications such as high speed air or electric hoists, vacuum lifters, or magnets.

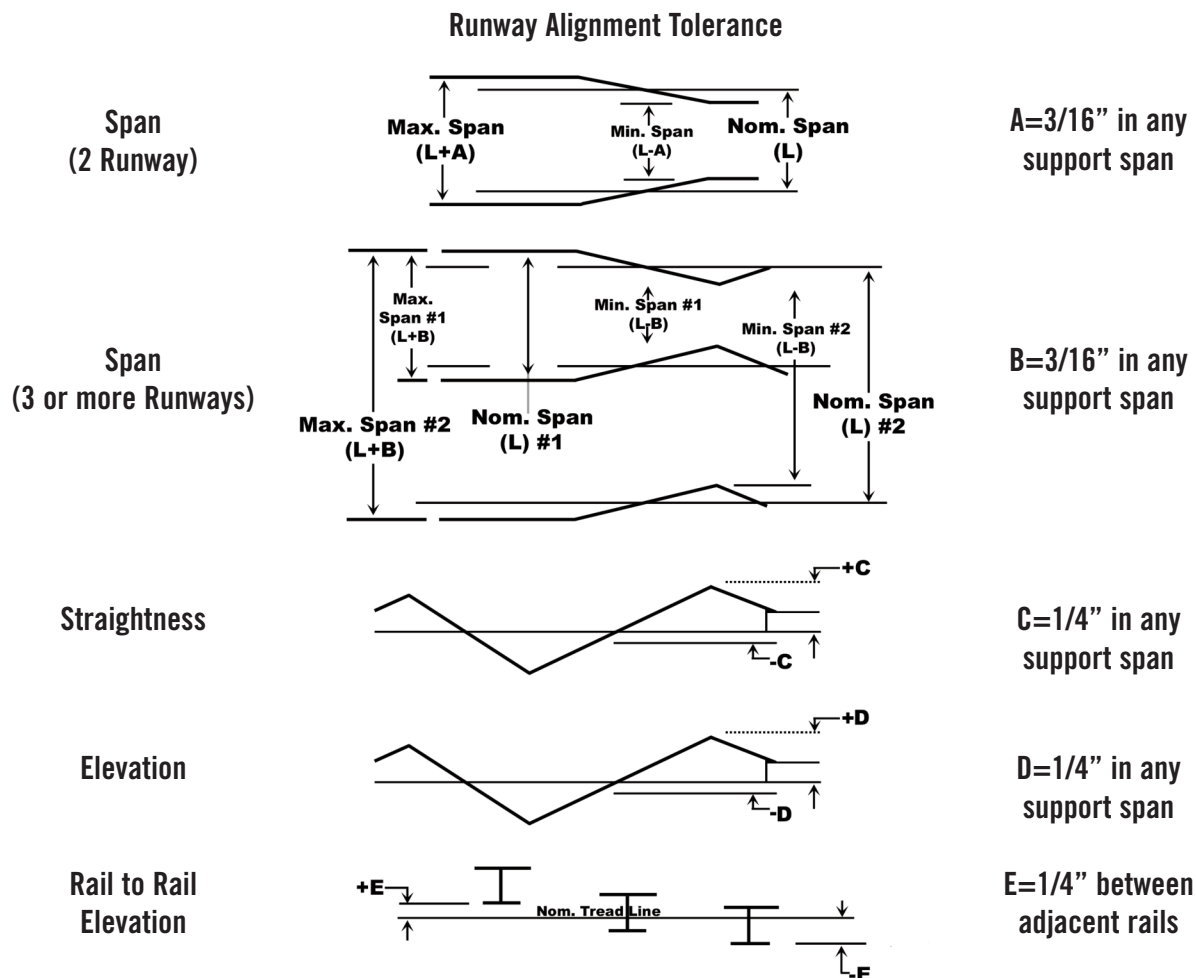

Because SPANCO Enclosed Track System provides a very high ease of movement, SPANCO recommends bridge and runway slope of no more than 1/4" in 20'-0" to prevent drift of bridge on trolley. Diagrams courtesy of Monorail Manufacturers Association MH27.1 and MH 27.2

# HEADER TO HEADER CONNECTIONS

(OPTIONAL)

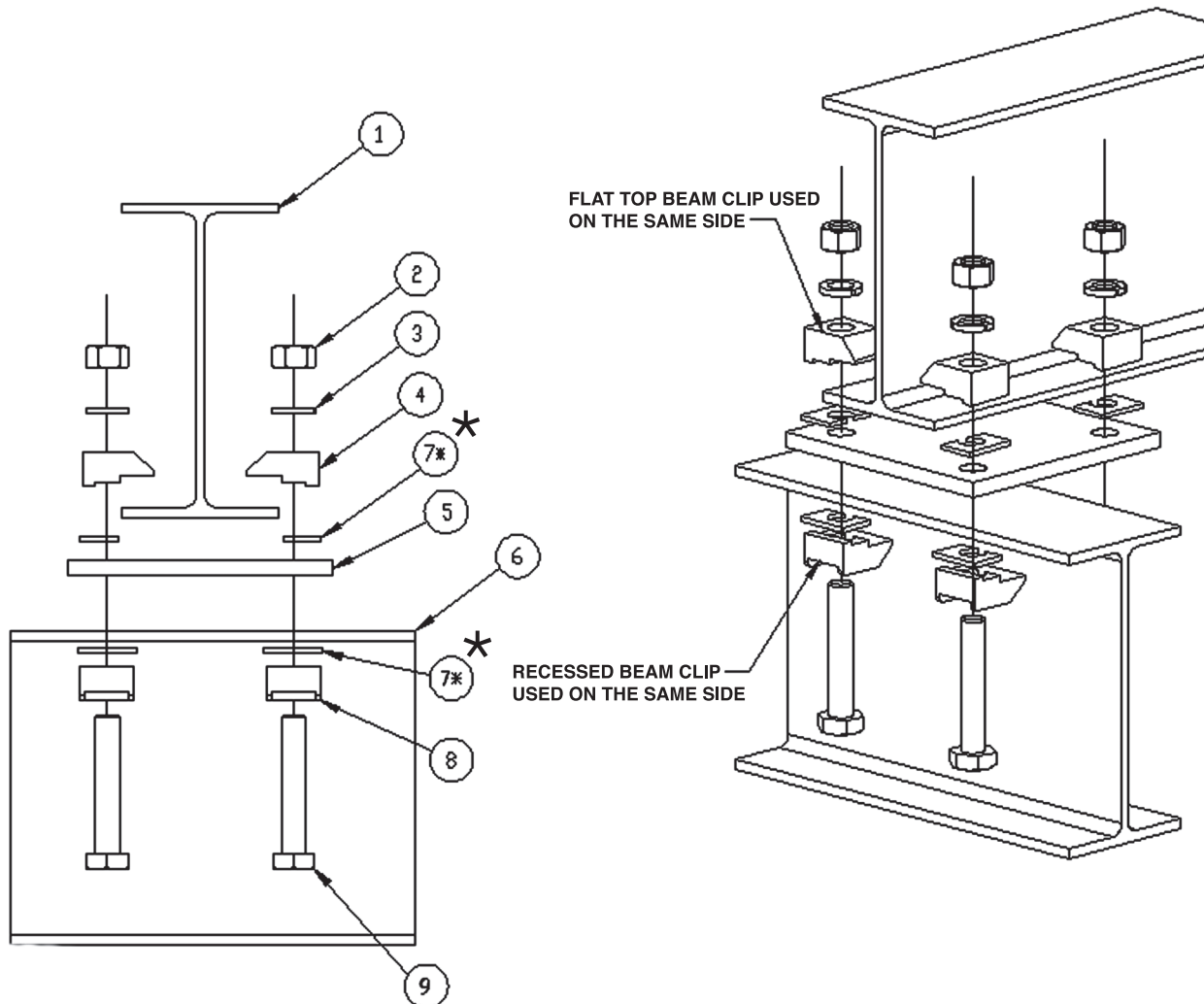

1. Header
2. (4) Hex Nut (5/8" or 3/4")
3. (4) Lock Washer (5/8" or 3/4")
4. (4) Beam Clip "B" (Smooth Top)
5. (1) Connection Plate
6. Header
7. Clip Washer \*
8. (4) Beam Clip "A" (Recesses Top)
9. (4) Bolt (5/8" or 3/4")

**\*\*NOTES\*\***

**TORQUE ALL BEAM CLIP FASTENERS**  
 5/8" DIA. 108 FT./lbs.  
 3/4" DIA. 210 FT./lbs.

\* CLIP WASHER OR PACKING MAY BE REQUIRED TO ACCOMMODATE THICKER FLANGES. THESE ARE NOT ALWAYS NEEDED.

# PLAIN TRACK REVERSE FLUSH MOUNT

(OPTIONAL)

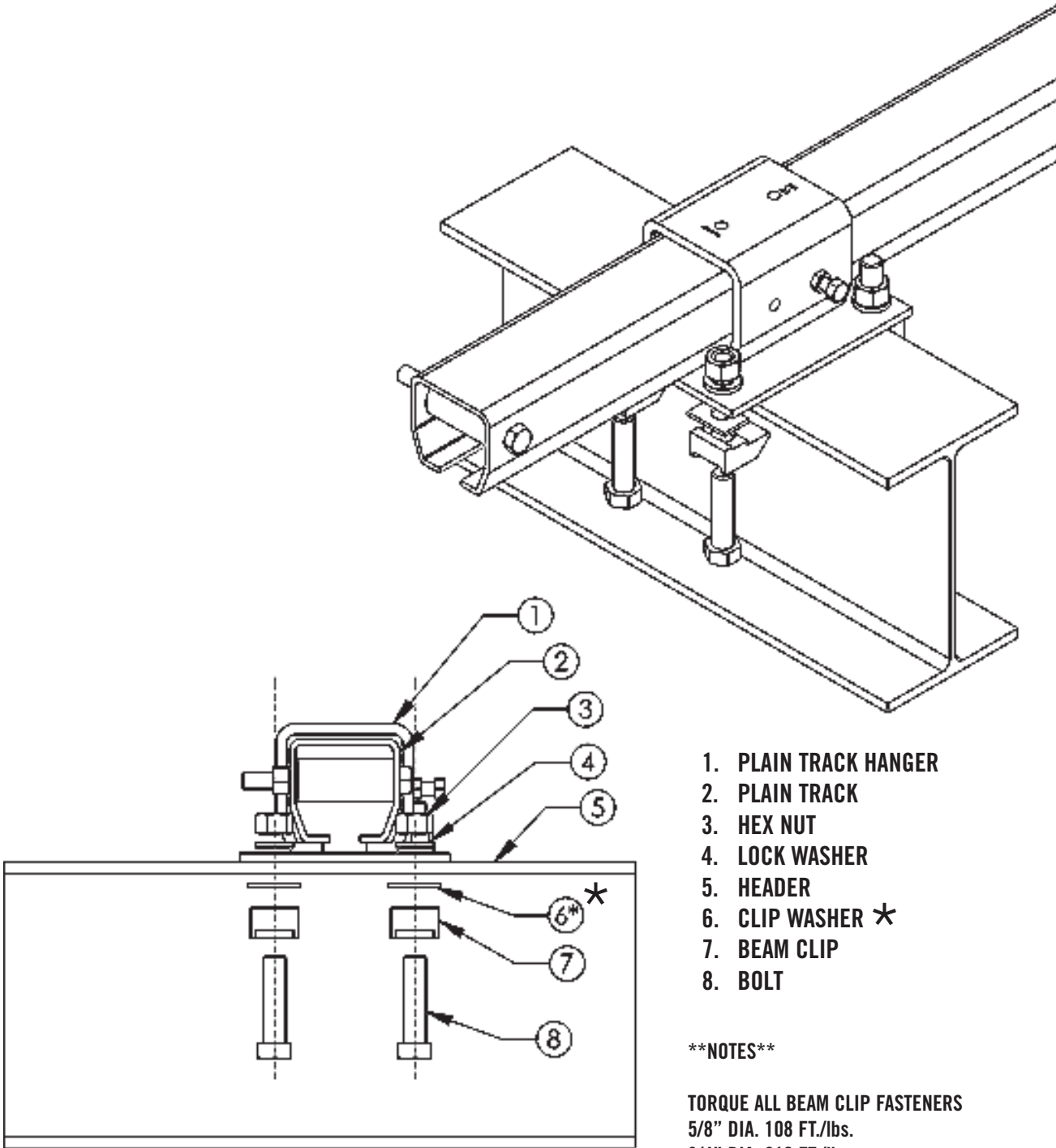

\* DEPENDING ON FLANGE THICKNESS, CLIP WASHERS, PACKING AND/OR NOTHING MAY BE USED.

# RUNWAY HANGER TOP MOUNT

(OPTIONAL)

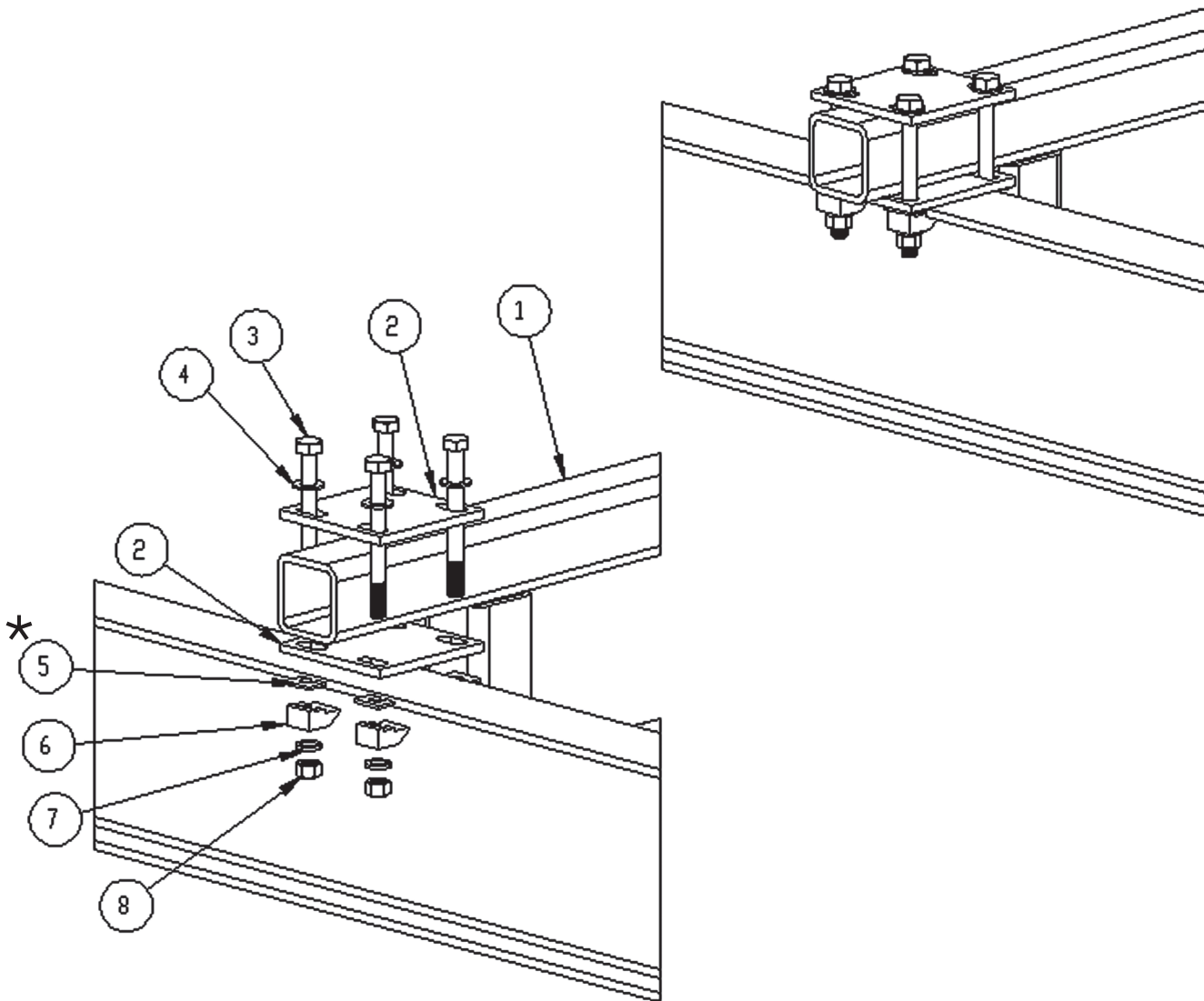

1. RUNWAY
2. (2) "PCT" PLATES
3. (4) FLAT WASHERS
4. CLIP WASHER \*
5. (4) BEAM CLIP
6. (4) LOCK WASHER (5/8" OR 3/4")
7. (4) HEX NUT (5/8" OR 3/4")

**\*\*NOTES\*\***

TORQUE ALL BEAM CLIP FASTENERS  
 5/8" DIA. 108 FT./lbs.  
 3/4" DIA. 210 FT./lbs.

\* CLIP WASHER OR PACKING MAY BE REQUIRED TO ACCOMODATE THICKER FLANGES. THESE ARE NOT ALWAYS NEEDED.

# ADJUSTABLE METHOD OF COLUMN ANCHORAGE

(OPTIONAL)

**ADJUST COLUMN HEIGHT BY  
ADJUSTING NUT HEIGHT.**

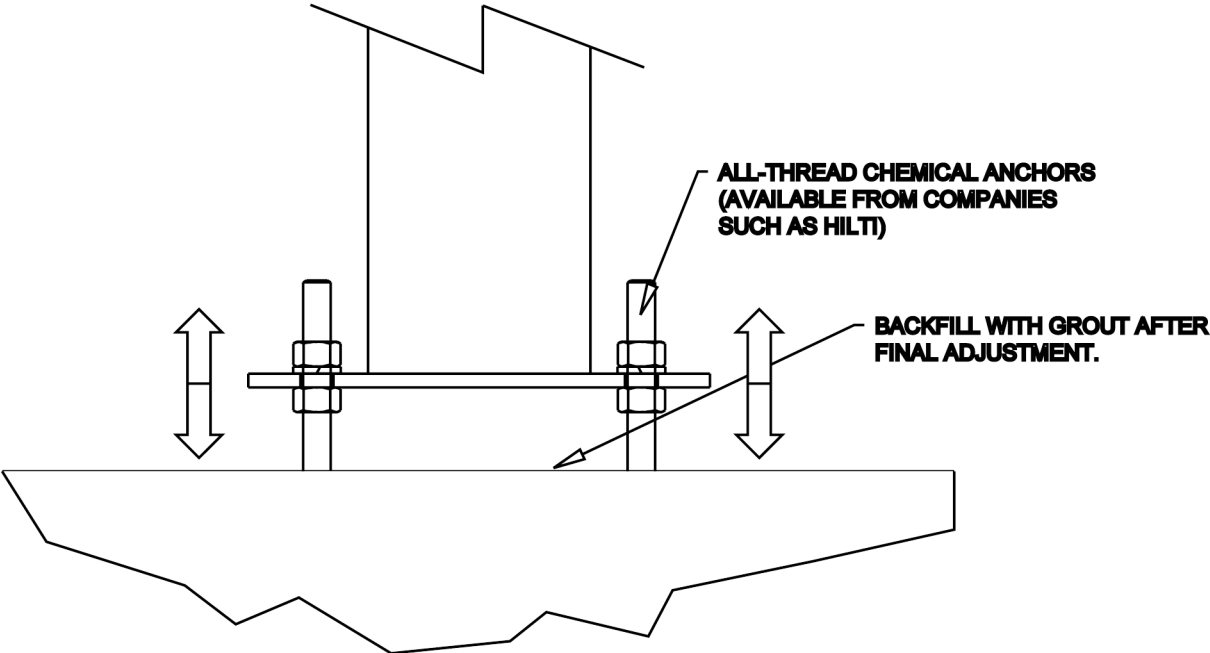



**Spanco, Inc.**  
604 Hemlock Road  
Morgantown, PA, 19543

Toll Free: 800-869-2080  
Local: 610-286-7200  
Fax: 610-286-0085

[Spanco.com](http://Spanco.com)

## TEN-YEAR SPANCO WARRANTY

### Products covered under the Ten-Year Warranty:

- Manual Steel Freestanding, Ceiling Mounted Workstation Bridge Cranes, and Monorails
- Manual Aluminum (Alu-Track®) Workstation Bridge Cranes and Monorails
- Manual Jib Cranes (I-Beam, Articulating, and Workstation Jib Cranes)
- Manual Gantry Cranes and Tripods

### What the Ten-Year Warranty covers:

- Defects in Equipment material and workmanship
- Wearable parts (end truck and hoist trolley wheels only)

Spanco, Inc. warrants its manual workstation bridge crane products, jib crane products, and gantry crane products to be free from defects in material and workmanship for a period of ten (10) years or 20,000 hours, commencing on the date of shipment to the first retail purchaser. This warranty extends to non-wearable parts only, with the exception of the wheels supplied on manually operated workstation end trucks and hoist trolleys. This warranty does not cover defective equipment or system failure caused by misuse, negligence, improper installation or maintenance, or equipment that has been used in excess of its rated capacity or beyond its service factors. It does not apply to equipment that has been altered without Spanco's written authorization.

Written notice of any claimed system defect must be given to Spanco within thirty days of discovery. Spanco's obligation under this warranty is limited to the replacement or repair of Spanco's products at the factory or separate location approved by Spanco. The purchaser is responsible for all freight and transportation costs relating to equipment repair or replacement. **Other than the abovementioned warranty, Spanco will not honor any other warranties—whether express, implied, or statutory—and disclaims any warranties of merchantability or fitness for a particular purpose. Spanco is not liable—under any circumstances—for any indirect, incidental, or consequential damages including but not limited to lost profits, increased operating costs, or loss of production.**

This warranty does not extend to components or accessories not manufactured by Spanco. The purchaser's remedy for such components and accessories will be determined by the terms and conditions of any the warranty provided by the manufacturer of such components and accessories.

**NOTE:** *All motorized Spanco products come with a One-Year Warranty on drive components.*