

HEAD OFFICE
Newall Measurement Systems Ltd.
 Technology Gateway, Cornwall Road
 South Wigston
 Leicester LE18 4XH
 United Kingdom
 Telephone: +44 (0)116 264 2730
 Facsimile: +44 (0)116 264 2731
 Email: sales@newall.co.uk
 Web: http://newall.com

Newall Electronics, Inc.
 1803 O'Brien Road
 Columbus, OH 43228
 Telephone: +1 614 771 0213
 Toll Free: 800.229.4376
 Facsimile: +1 614 771 0219
 Email: sales@newall.com
 Web: http://newall.com

Custom Sensors & Technologies
 11F Chang Feng International Tower
 89 East Yunling Road
 Shanghai, 200062 China
 Tel: +86 21 8025 7166
 Fax: +86 21 6107 1771
 E-mail: sales@newall.cn
 web: www.newall.cn

Custom Sensors & Technologies
 No 23 Trident Towers 4th Floor
 100 Fleet Ashoka Pillar Road
 2nd block Jayanagar - Bangalore
 560 011 - India
 Tel: +91 80 4113 2204/05
 Fax: +91 80 4113 2206



023-82150-UK/0

A full hard copy of the manual is available free of charge on request

NEWALL Spherosyn LT & Microsyn LT Quick Install Guide

For the complete installation manual, please download from:
<http://newall.com>, Click Technical Support to access the download page.

Preparation

Prior to beginning the installation the machine should be studied to determine the Encoder(s) position and to ensure the brackets are suitable or if custom brackets are required.

In order to reduce erroneous readings caused by machine wear, it is recommended that the encoder be fitted as close to the machine lead screw or axial drive shaft as possible.

Warnings

If for any reason the machine axis travel is greater than the actual scale travel 'mechanical stops' should be fitted to the machine to avoid damage caused by over travel. Newall will not accept responsibility for encoder damage caused by machine over travel.

It is important the Scale be kept at least 13mm (0.5") away from any magnetic sources such as magnetic bases or chucks.

Assembly Diagrams

Figure 1 - Spherosyn LT Encoder Assembly

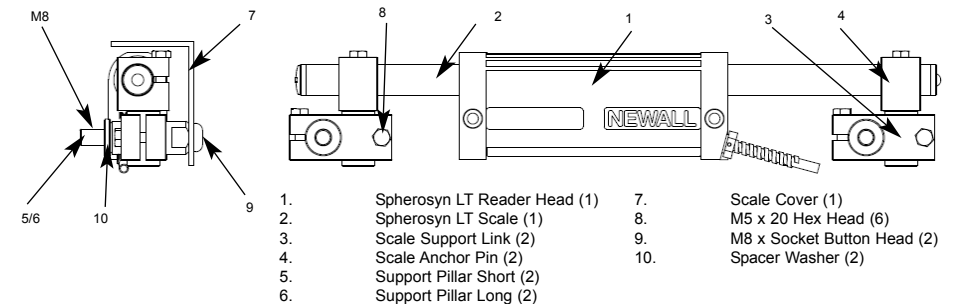
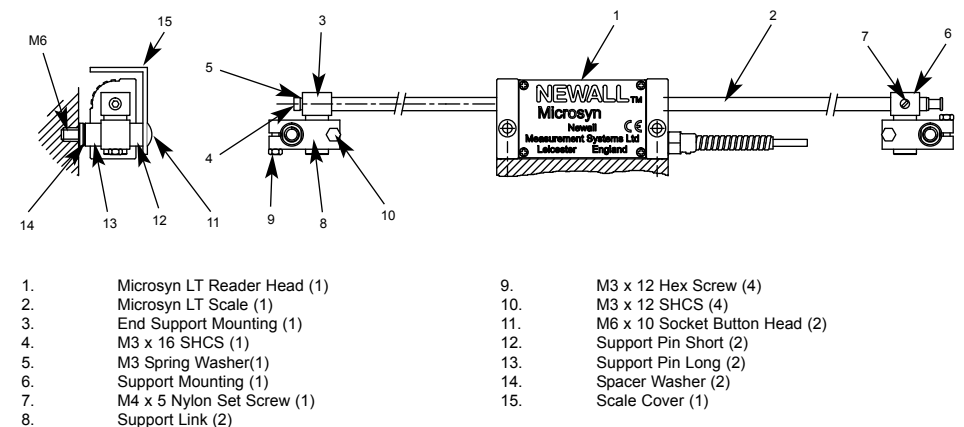

Figure 2 - Microsyn LT Encoder Assembly



Reader Head Alignment

Mounting Faces

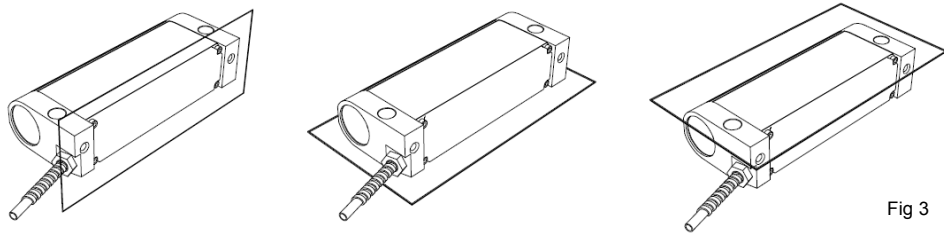

Fig 3

The Reader Head can be mounted on any 3 of the faces shown in fig 3.

Alignment Tolerance to machine

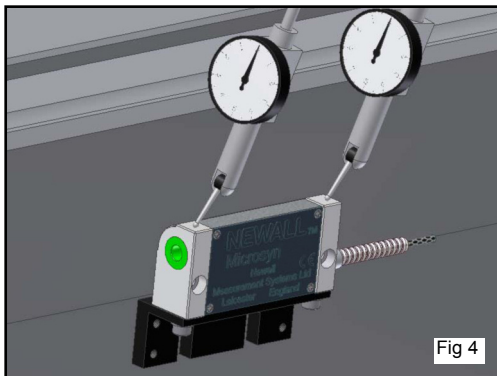

Fig 4

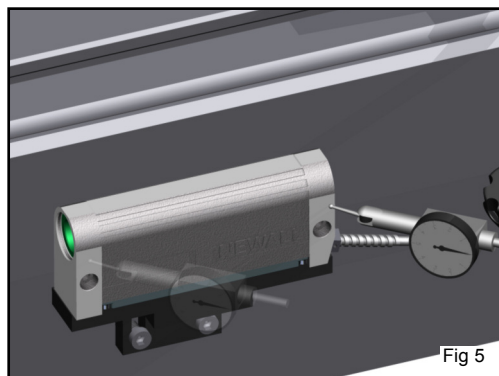

Fig 5

The reader heads should be mounted with both planes parallel to the axis of travel within +/- 0.05mm(0.002"). See fig 4 and 5.

Scale Mounting - Double Ended

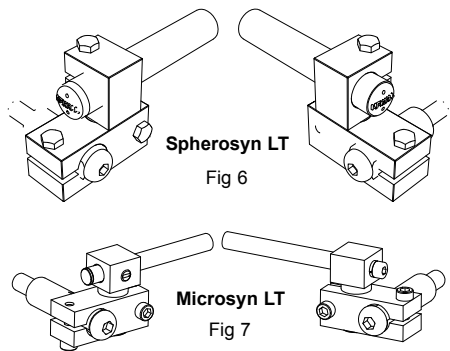
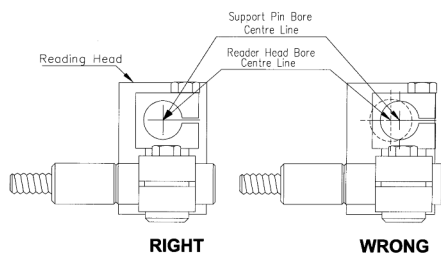

Fig 6

Fig 7



RIGHT

WRONG

Traverse the machine to its maximum position towards the non cable entry side of the reader head. Slide scale through reader head and fit assembly (fig 6 & 7) onto end of scale. Mark the position of the pillar.

Drill & tap to suit pillar (fig 1 & 2). Loosely fit assembly to pillar, pass scale through, slide scale forwards and back whilst tightening the screws until it passes smoothly through head and bracket. Once aligned repeat at the other end.

Scale Mounting - Single end (300mm (12") travel or less)

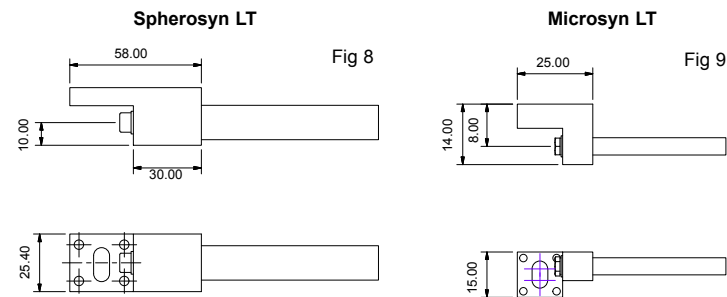

Fig 8

Fig 9

For Spherosyn LT remove the white nylon snap rivet from end of scale. **Do not tamper with the adjustment set screw as this will alter the calibration.**

Once reader head is aligned, slide the scale through and into the single end support and secure into place.

Position the block in the correct position, mark the slot. Drill & tap to suit fixing (fig 8 & 9).

Once secured check alignment by gently sliding scale in and out through head and block. Grub screws are available for adjustment.

You can single end mount with the standard link, pillar brackets or with the optional single end mount brackets shown above.

Fitting the Scale Guard

Each Encoder includes a protective guard. The guard can be attached to the machine casting or by means of the scale support pins via the button head screws provided.

For single end mounting use machine faces.

After the guard is attached, move the machine axis to both extents of its travel ensuring that the guard does not interfere with or rub against the Reader Head.

Cable Routing

Care should be taken to ensure that all cables are routed and secured to the machine avoiding any mechanical interference with any part of the machine or encoder movement. Routing should also avoid sources of electrical noise and interference. Cable clamps are supplied.

Note: The armoured cable is an integrated part of the reader head. If the cable becomes damaged this will require a replacement reader head. Ensure all connectors are located in a position to avoid fluid contamination.

Final Check

Prior to putting the linear encoder system into operation after installation, slowly traverse the machine axis to ensure that all cable routings are correct and machine over-travel cannot occur.