

AEROEX

TECHNOLOGIES

MAV-2000

BROCHURE



MADE IN NORTH AMERICA.
TRUSTED BY ALL.



PRODUCT DESCRIPTION

MAV-2000

Demanding applications require proven performance in the toughest environments—whether it's coolant mist, oil mist, or smoke. The Maverick MAV-2000 meets these requirements out of the box with a standard HEPA filter, up to 99.97% efficiency on submicron particles and guaranteeing clean air even under heavy-duty conditions.

Minimizing downtime and service costs is critical. The MAV-2000's multi-stage filtration system, featuring industry-leading fibrebed media, extends filter life to 3–5 years (application-dependent) and dramatically reduces replacement frequency. Because filter stages are modular, you can tailor the configuration—add carbon cells for fume control or swap in specialized media—to match each process, ensuring you're never over or under-filtered. Each MAV-2000 is also equipped with drains for continuous drainage, returning separated coolant or oil directly to your machine.

Integration needs vary across shops, so the MAV-2000 offers true flexibility. Mechanically, choose between horizontal suction (for duct or hose connections) or bottom-suction direct mounting via Aeroex's proprietary baseplate system. Electrically, Aeroex provides a suite of integration kits that let you run the MAV-2000 from your machine tool's control logic—adding automation even where the CNC doesn't natively support it. If you prefer standalone control, panels and VFDs are also available.

Real-time feedback keeps maintenance truly proactive. Two digital service gauges—with 4–20 mA outputs and alarm signals—connect to your remote monitoring systems, reporting filter status continuously. Dual-color (green/red) status lights give operators an instant visual check.

In summary, the MAV-2000 combines HEPA-level efficiency, long-life fibrebed filtration, application-specific adaptability, seamless mechanical and electrical integration, and intelligent digital monitoring—delivering low-maintenance, high-performance mist collection wherever you need it.



KEY MAVERICK FEATURES

- Digital Gauges
- Status Lights
- Vertical and Horizontal Suction
- Mounting Baseplate

PRODUCT SPECS

Air Flow	1800 - 2000 cfm
Machine Tool Enclo. Recom Volume	Up to 2000 ft ³
Motor	3 hp
Voltage (Amps)	230/3/60 (7.6) 460/3/60 (3.8) 575/3/60 (2.9)
Inlet Connection	12"Ø
Sound	71 dB(A)
pH limit	5.8 - 12

Temp limit	70 °C / 160 °F
Weight	390 lbs
Length	43.5"
Width	29"
Height	52.3" (with base feet)
HEPA Filter	Standard
Carbon Filter	Optional

FILTER TECHNOLOGY

The MAV-2000's filter system is engineered to deliver unrivaled air purity, long service life, and simple service—ensuring your shop stays clean and productive without constant downtime. At its core is our industry-leading fibrebed media, designed with progressive-efficiency stages that trap coolant mist, oil aerosols, and smoke particles down to microns with minimal pressure drop. Because the fibrebed is resistant to clogging, you'll typically see 3–5 years of filter life (application-dependent), dramatically reducing replacement costs and labor.

Understanding that every shop has unique needs, the MAV-2000 features a fully modular filter setup. The standard assembly includes a mechanical stage and fibrebed media with HEPA for submicron capture, while activated carbon cells can be added for vapor and fumes, or stages swapped with specialty media to suit specific applications. Quick-mount rails and ergonomic handles enable fast, easy field changes, allowing you to adapt your filtration as processes evolve.

Built-in drains at the primary separation stage return collected coolant or oil directly to your machine tool, minimizing fluid waste. Digital gauges let operators monitor remaining media life instantly—no guesswork, no disassembly. When it's time for a swap, individual panels slide out without disturbing adjacent stages, cutting maintenance to mere seconds.

Whether handling high-volume machining, heavy-duty grinding, or specialized chemical processes, the MAV-2000 filter suite offers flexible configuration, long-lasting fibrebed filtration, standard HEPA, optional carbon polishing, and built-in hands-free drainage—all in an easy-to-service design. This ensures reliable air-quality compliance, reduced ownership costs, and confidence that your filtration performs at its best.

FILTER BREAKDOWN

- 1. 1st Stage: Mechanical Element:** This stage uses smooth metal surfaces and strategically placed baffle plates to separate up to 90% of heavier oil mist and swarf from the airflow. The separated fluids quickly drain back to the machine sump, reducing waste and preventing premature filter saturation downstream.
- 2. 2nd Stage: Demister Element:** The Demister Element supports the first stage of filtration, capturing and removing up to 95% of mist and swarf particles. It uses durable, washable filters designed for long-term use, making it a non-consumable solution.
- 3. 3rd Stage: Pleated Depth-Loading Fibrebed Filter:** Building on the previous stage, this filter offers higher efficiency by capturing finer mist and smoke particles. Its advanced depth-loading construction provides a significantly increased surface area compared to standard filters, which improves filtration capacity and helps extend service intervals.
- 4. 4th Stage: Pleated Depth Loading Fiber Bed Filter:** Rated MERV 14, this high-performance filter features a depth-loading design that provides up to 25 times more surface area than standard filters. This increased capacity significantly extends its service life, typically lasting between 2 to 4 years depending on usage and environment.
- 5. 5th Stage – Certified HEPA Filter:** This final polishing stage is available in two efficiency options—95% or up to 99.97%—and captures the smallest submicron particles, including mist, smoke, and aerosols. Designed for critical air quality, it ensures the exhaust air meets stringent environmental and safety standards.



FILTERS OVERVIEW

The Maverick mist collectors offer versatile, easy to install filters for diverse applications including Fibrebed depth loading and HEPA. Quick self-replacement reduces downtime and external maintenance needs. * Activated carbon and custom media options are also available.

REPLACEMENT FILTERS



1ST STAGE MECHANICAL ELEMENT
A20FMS-0001



2ND STAGE DEMISTER ELEMENT
A20FDE-0002



3RD STAGE "OM#5" OIL MIST FIBRE BED FILTER
A20FOM-0005



4TH STAGE "OM#7" OIL MIST FIBRE BED FILTER
A20FOM-0007



5TH STAGE "HF" HEPA FILTER
95% 2000HF-2095
99.97% 2000HF-2099
Odor-Rid 2000HF-3095

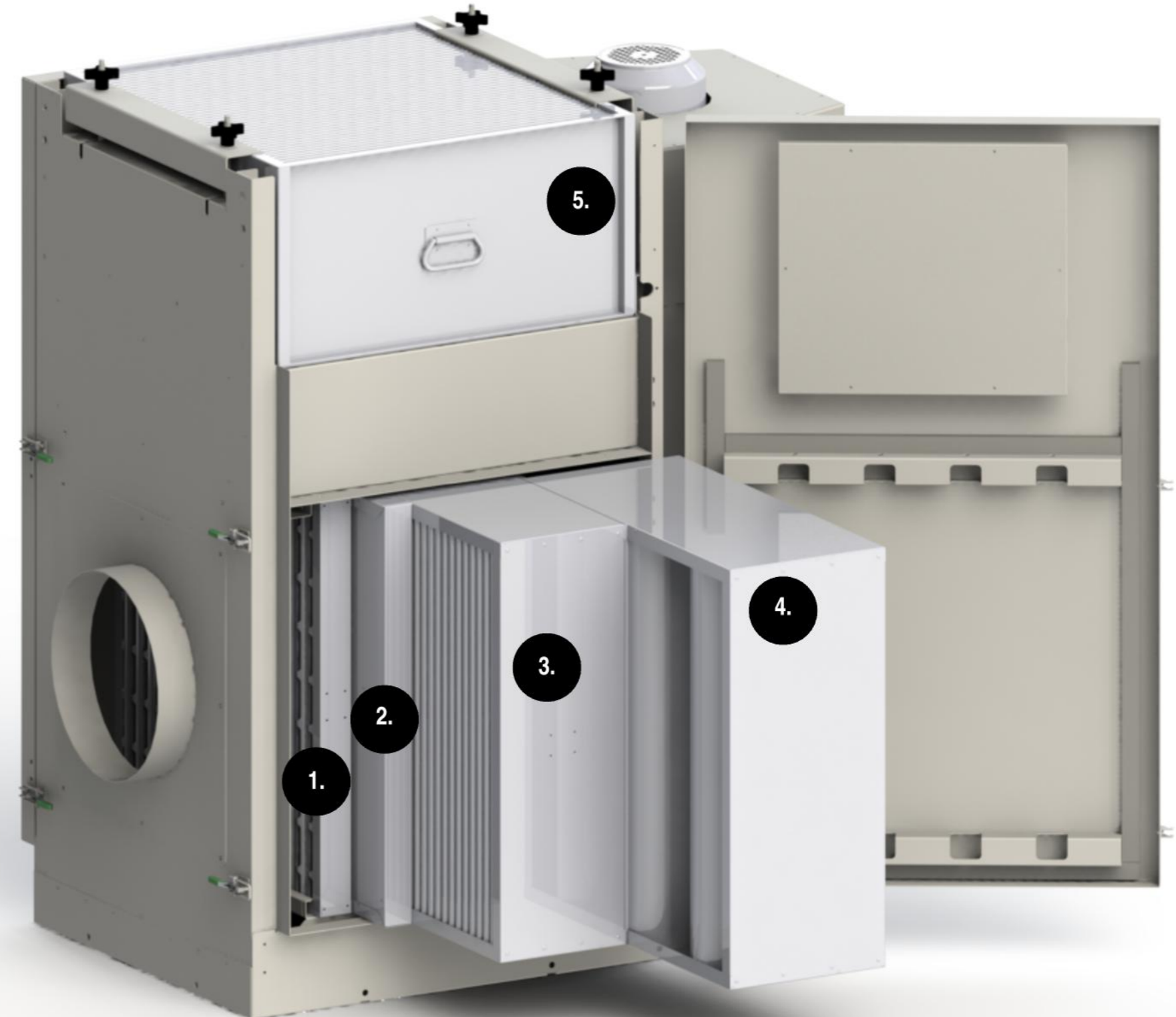

MAV-2000

AEROEX

KEY FEATURES

SETTING A NEW STANDARD

The Maverick mist collector is engineered with advanced features to deliver reliable performance and low service needs in the most demanding machining applications.

Designed for ease of use and seamless integration, it combines intelligent digital monitoring, electrical integration, and flexible installation options to optimize filtration efficiency while minimizing downtime and maintenance effort. Below is a detailed breakdown of the key features that set the Maverick apart.

1. DIGITAL GAUGES

Equipped with digital gauges featuring 4–20 mA outputs and alarm signals, the system provides real-time monitoring of internal pressure levels for precise feedback on filter condition and airflow efficiency. This enables proactive maintenance and helps prevent unexpected downtime.

2. STATUS LIGHTS

Dual-color status lights offer immediate, at-a-glance insight into system performance and maintenance needs, helping operators quickly identify when service is required.

3. VERTICAL OR HORIZONTAL SUCTION

Designed for flexibility, the Maverick supports both horizontal inlet connections for duct or hose setups and vertical suction for direct machine mounting, adapting effortlessly to your shop's configuration.

4. MOUNTING BASEPLATE

A proprietary mounting baseplate system simplifies machine integration by providing a secure, mechanically compatible platform that ensures stable, vibration-resistant installation.

5. ELECTRICAL INTEGRATION KITS

Aeroex offers a range of electrical integration kits that enable automated control of the Maverick mist collector via your machine tool, adding start/stop functionality and safety interlocks even when native machine control is not available.



MOUNTING OPTIONS

FLEXIBLE MOUNTING SOLUTIONS TAILORED TO YOUR WORKSPACE

The Maverick mist collector is designed with versatility in mind, offering multiple mounting options to fit a wide range of shop layouts and operational needs. Whether space is limited, equipment moves frequently, or centralized mist collection is preferred, our adaptable mounting solutions ensure efficient mist capture without disrupting your workflow. Explore the choices that make integrating the Maverick effortless and effective.

DIRECT MOUNT

Install the mist collector directly on your machine tool. Ideal for compact spaces, it captures mist right at the source, significantly reducing airborne contaminants while providing a clean, integrated appearance that blends seamlessly with your equipment.

SUSPENDED MOUNT

Suspend the Maverick mist collector from the ceiling or overhead supports. Perfect for saving floor space and suited for both centralized mist collection systems or servicing individual machines.

WALL MOUNT

Use vertical wall space to free up floor area. This option is great for smaller workshops or where direct or suspended mounting isn't practical.

STAND AND HOSE

Mount the mist collector on our sturdy pillar stand and connect it to your machine using a suction hose. This setup provides versatile connection options while keeping the collector separate from the machine for easier access and flexible placement.

Choose the mounting style that best fits your space and operational goals. By aligning your selection with your facility's layout and workflow, you'll optimize mist collection efficiency while keeping production running smoothly.



Example of a
Direct Mount.

MAV-2000

AEROEX

ACCESSORIES

INSTALLATION



SUSPENSION BRACKET

MAV 400 & MAV 600 099AMW-0001
 MAV 1100 & MAV 1400 099AMW-0002
 MAV 2000 099AMW-0003



INSTALLATION KIT

MAV 400 099AKI-0001
 MAV 600 & MAV 1100 099AKI-0002
 MAV 1400 099AKI-0003
 MAV 2000 & MAV 2500 099AKI-0004



STAND

32" Tall Powder coated black
Only for MAV 400
 099AMP-0004



WALL MOUNT

MAV 400 & MAV 600 099AMW-0001
 MAV 1100 & MAV 1400 099AMW-0002
 MAV 2000 099AMW-0003



PILLAR STAND

MAV 400 & MAV 600 099AMP-0061
 MAV 1100, MAV 1400 & MAV 2000 099AMP-0062
 MAV 2500 099AMP-0063

MISCELLANEOUS



CHIP STRAINER

MAV 400 & MAV 600 099ACS-0002
 MAV 1100 099ACS-0005
 MAV 1400 099ACS-0006
 MAV 2000 & MAV 2500 099ACS-0007



SUCTION HOSE

MAV 400 099MPH-0006
 MAV 600 & MAV 1100 099MPH-0008
 MAV 1400 099MPH-0010
 MAV 2000 & MAV 2500 099MPH-0012



HOSE CLAMP

MAV 400 099AHC-0006
 MAV 600 & MAV 1100 099AHC-0008
 MAV 1400 099AHC-0010
 MAV 2000 & MAV 2500 099AHC-0012



MACHINE ADAPTER

MAV 400 099AMS-0006
 MAV 600 & MAV 1100 099AMS-0008
 MAV 1400 099AMS-0010
 MAV 2000 & MAV 2500 099AMS-0012



WIRE KIT

MAV 400 & MAV 600 099EMS-E001
 MAV 1100 & MAV 1400 099EMS-E002
 MAV 2000 099EMS-E003
 MAV 2500 099EMS-E004
 MAV 4000 099EMS-E005

REPLACEMENT PARTS

MOTOR

MODEL	VOLTAGE	
	230/460/3/60	575/3/360
MAV 400 / 600	099EMT-0002	099EMT-0003
MAV 1100/1400	099EMT-0010	099EMT-0011
MAV 2000	099EMT-0006	099EMT-0007
MAV 2500/4000	099EMT-0008	099EMT-0009



IMPELLER

MAV 400 A04IMP-001
 MAV 600 & MAV 1100 A06IMP-001
 MAV 1400 & MAV 2000 A14IM0-001
 MAV 2500 & MAV 4000 A25IMP-001



INLET CONE

MAV 400 A04CON-0001
 MAV 600 & MAV 1100 A06CON-0001
 MAV 1400 & MAV 2000 A14CON-0001
 MAV 2500 & MAV 4000 A25CON-0001



DIGITAL GAUGE

MAV-A031
 MAV 2500 & MAV 4000 receive primary and HEPA status gauge

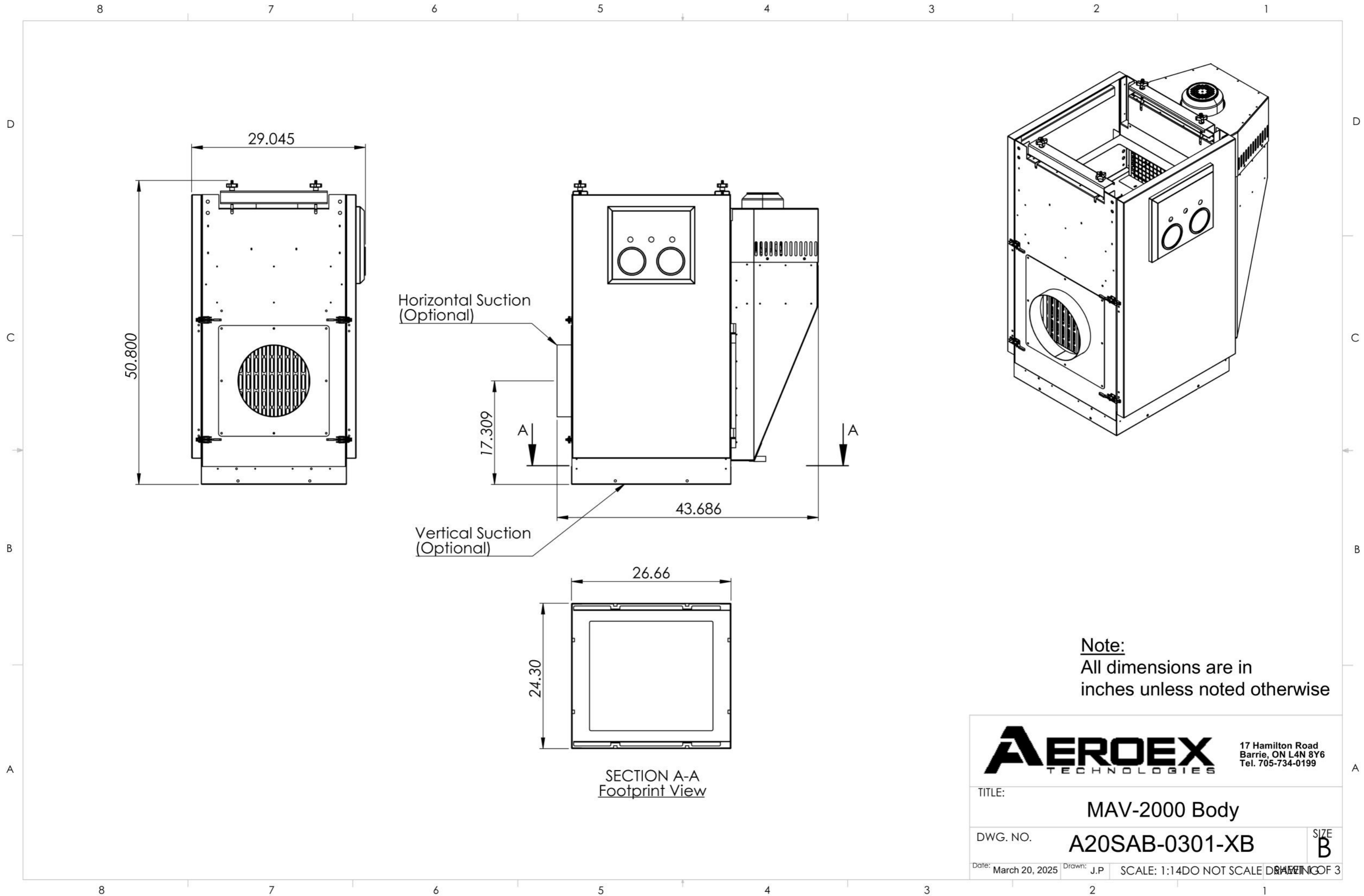

<p>AEROEX TECHNOLOGIES</p> <p>17 Hamilton Road Barrie, ON L4N 8Y6 Tel. 705-734-0199</p>	
TITLE: MAV-2000 Body	
DWG. NO. A20SAB-0301-XB	SIZE B
Date: March 20, 2025 Drawn: J.P.	SCALE: 1:14 DO NOT SCALE DRAWING

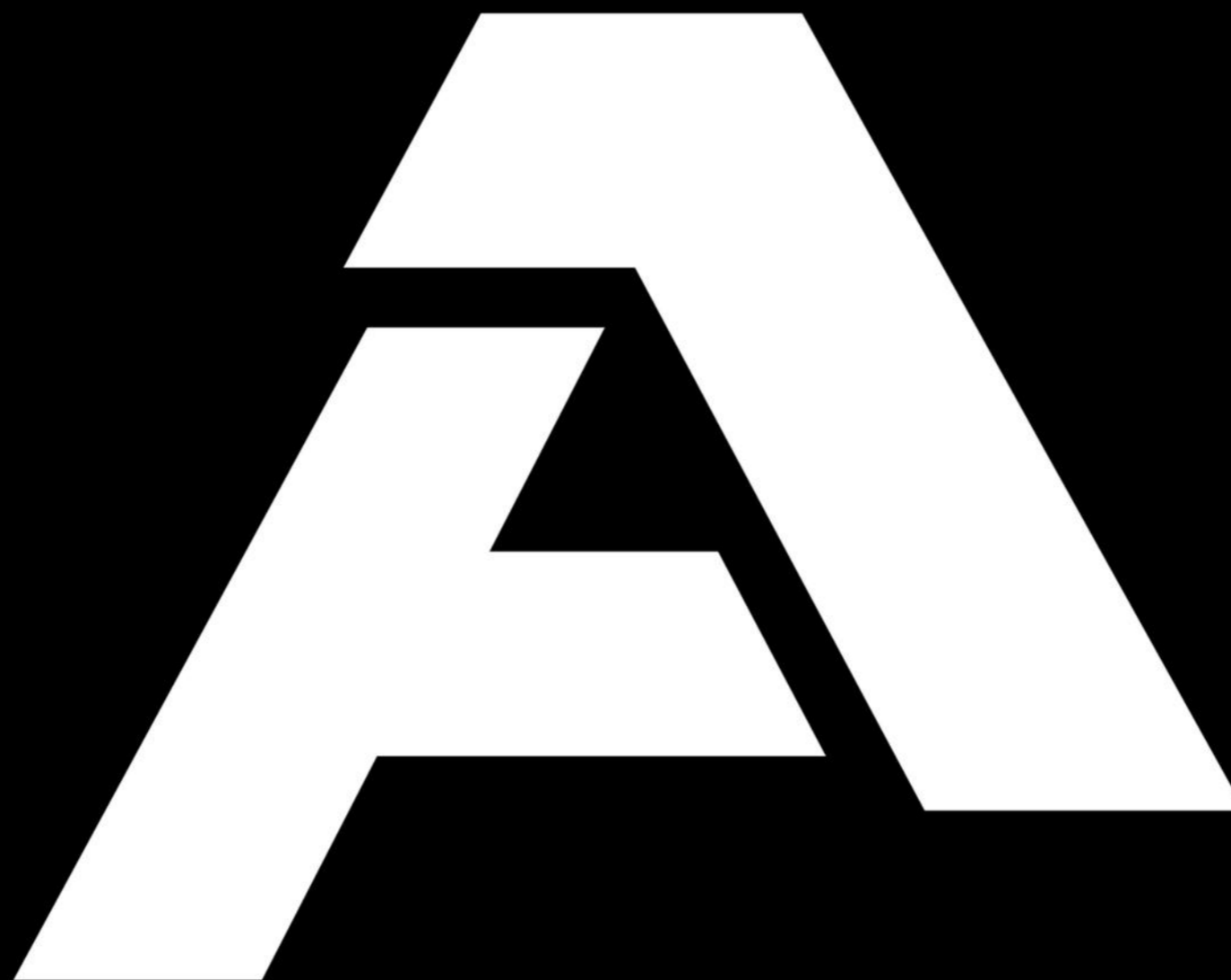

AEROEX TECHNOLOGIES
717 Bayview Dr.
Barrie, ON L4N 9A5

AEROEX U.S.A.
10585 47th St. N.
Clearwater, FL 33762

Aeroex.com
866-392-9222
sales@aeroex.com
orderdesk@aeroex.com

Mav2000_Brochure_V3_2026-03