

ACU-RITE®

VUE LCD Digital Readout Systems

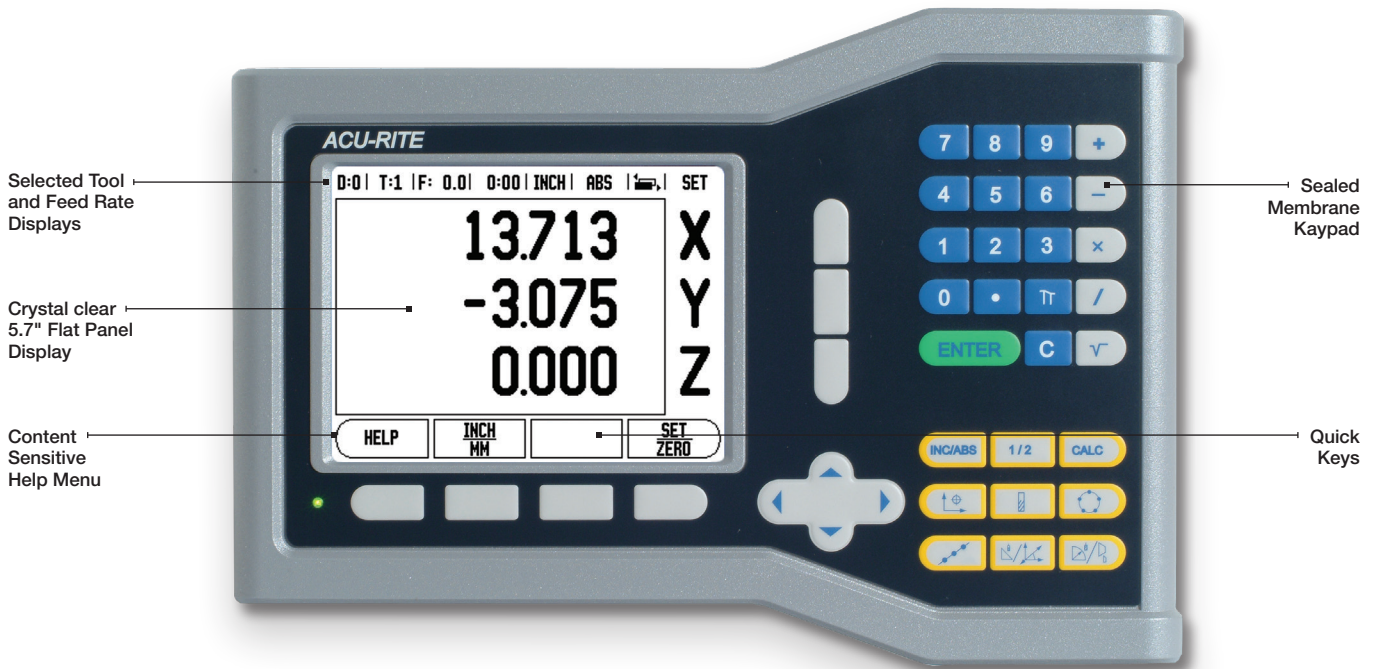

The most cost effective, entry level digital readout system that incorporates flat panel display technology, the VUE offers many popular features and versatile software to accommodate milling, turning and grinding applications. Designed and manufactured in the USA, ACU-RITE readouts are the first choice of machine tool builders and users alike.

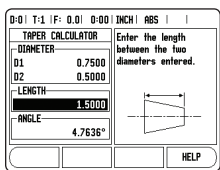

Turning Applications

Menu driven taper calculator provides machine to zero ease of use.

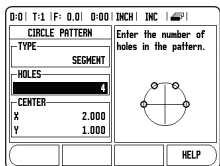

Milling Applications

Bolt hole pattern calculations for full and partial circles with on screen graphics.

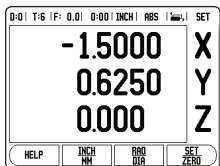

Grinding Applications

Increase the speed and accuracy of grinding and general purpose applications.

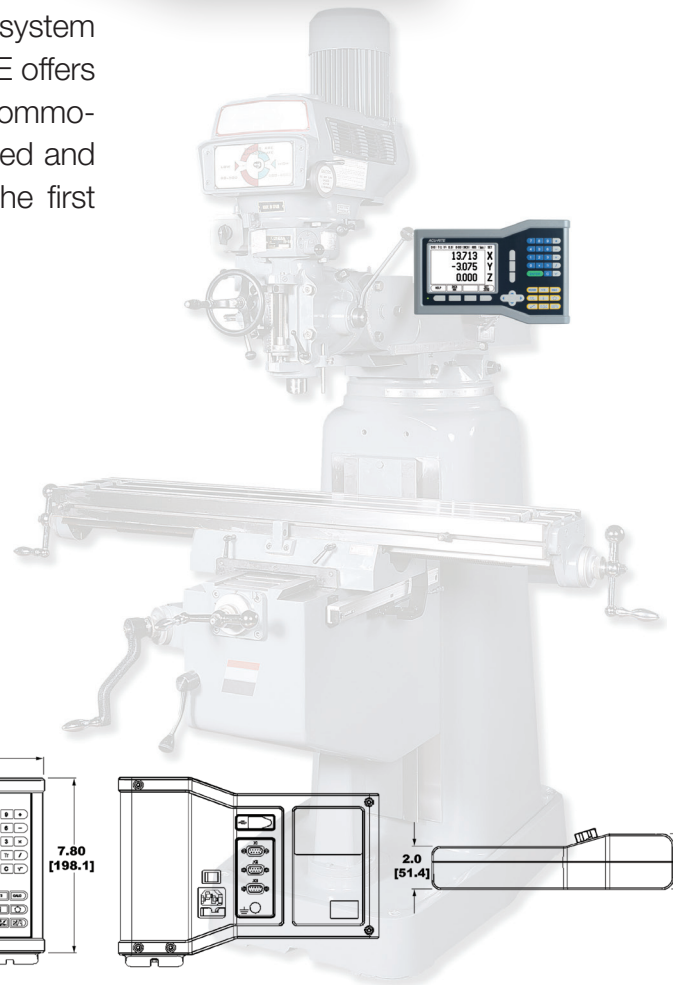
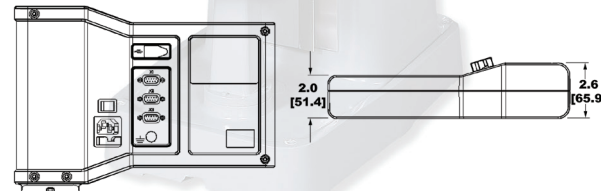
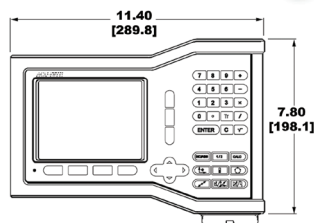

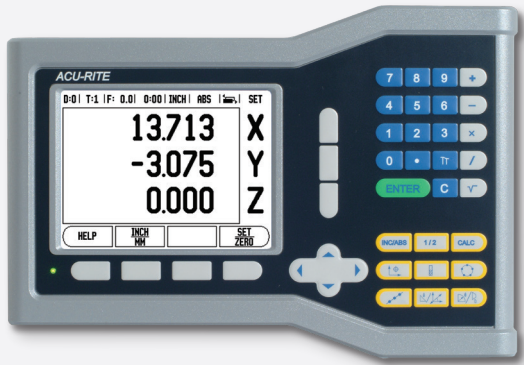
VUE Technical Data	
Display	<ul style="list-style-type: none"> • 1, 2 or 3 Axes • 5.7" Monochrome Flat Panel Display
Common Functions	<ul style="list-style-type: none"> • Job Clock • Feed Rate Display • Multiple Language Support • Absolute/Incremental • Near-Zero Warning with Graphics • Help Function • 16 Tool Offsets/Diameter • Preset and Zero Reset • 4 Function Calculator/Trig Calculator • Instant Inch/mm Conversion • Linear/Non-Linear Compensation up to $\pm 9,999$ ppm 
Milling Specific Functions	<ul style="list-style-type: none"> • Bolthole Pattern Calculations with Graphics (<i>full and partial circles/linear patterns</i>) • Centerline Calculation <i>establish workpiece zero and midpoints</i>
Turning Specific Functions	<ul style="list-style-type: none"> • Lock Axis Feature <i>establish tool offsets with the tool under load, resulting in reduced tool deflection.</i> • Instant Radius/Diameter Conversion • Taper Calculator • Vectoring
Options	DRO Stand, Mounting Arm, Mounting Frame
Construction	Die-Cast Metal
Weight	5.20 lbs.
Data Interface	Serial Communication via USB Type B for Software Downloads
Electrical Requirements	<ul style="list-style-type: none"> • Voltage of 100-240 VAC. • Power of 25 VA max. • Frequency of 50/60 Hz (+/-3Hz)
Operating Temperature	0° to 45° C (32° to 113° F)
Storage Temperature	-20° to 70° C (-22° to 158° F)
Protection EN60529	IP 40, Front Panel IP 54

With more than one million in use today, ACU-RITE® Precision Glass Scales withstand the elements of even the harshest machine shop environments. Built to resist changes in size, shape, or density due to temperature and humidity variations, this stability provides exceptional accuracy, resulting in tighter workpiece tolerances.

ACU-RITE® scales are available in travel lengths from 1" - 120" and in resolutions from 0.5µm (.00002") to 5µm (.0002").



ACU-RITE®

HEIDENHAIN CORPORATION

333 East State Parkway
Schaumburg, IL 60173-5337 USA

(847) 490-1191

(847) 490-3931

info@heidenhain.com

www.acu-rite.com



Certifications

ISO-9001, UL, CSA, CE